



**Invitation to Bid (ITB) and 2024171**  
***Lot Expansion and Improvements Project***

**Date Issued: August 9, 2024**

**Proposal Due: August 30, 2024**

Facilitator:  
Wade McMillian  
Procurement Project Administrator  
[wade.mcmillian@nashville.gov](mailto:wade.mcmillian@nashville.gov)  
615-862-5969

## INVITATION TO BID

MTA Main Office  
430 Myatt Drive  
Nashville, TN 37115

**BIDS MUST BE RECEIVED PRIOR TO**  
**1:00 pm CT**  
**Friday, August 30, 2024**  
**BID NUMBER**  
**2024171**

### INSTRUCTIONS:

1. SUBMIT (1) SEALED, ORIGINAL COPY OF THE BID and (1) ELECTRONIC COPY OF THE BID
2. ALL BIDS ARE TO BE IDENTIFIED WITH ITB#, ITB NAME, AND RETURNED VIA EMAIL DURING THE ITB PROCESS
3. ALL COMMUNICATION MUST BE DIRECTED TO PROCUREMENT DEPARTMENT.

---

Nashville Metropolitan Transit Authority (Nashville MTA), doing business as WeGo Transit, (hereafter may also be referred to as the "Agency," the "Authority," "WeGo Public Transit," or "WeGo") is soliciting bids from firms qualified to perform **Lot Expansion and Improvements**. See technical specifications for details.

( Bidders are advised that the procurement resulting from this solicitation will be funded with funds received from the Federal Transit Administration and the State of Tennessee.

**Bidders are to carefully review Exhibits A and B of the Contract Terms and Conditions** in Section VI, as all terms and conditions expressed in those Exhibits will apply to this procurement and resulting contract.

### PROJECT DESCRIPTION

The Lot Expansion and Improvements project aims to revitalize and enhance the functionality of the Myatt facility parking lots to serve as training grounds and testing area for Commercial Driver's Licensing (CDL) courses, primarily for WeGo bus drivers.

The present project addresses the rehabilitation and resurfacing of the existing Myatt facility lots, including addressing localized pavement structure failures, installing concrete slabs in areas of high use, installing a new access driveway on the NW corner of the parking lot, reestablishing stripping and marking of the certified CDL training courses.

Improvements also include the expansion of drivable area in the lot by replacing the existing grass strip with full structural pavement section. The project will also install a concrete platform to be used for training and installing one empty conduit for future electrical connections.

### \*\*\*SPECIAL NOTICE TO BIDDERS\*\*\*

**Bidders are to submit with their bid a copy of the required TN contractor's licenses for their firm.**

#### Bonding requirements:

- **Bidder must submit a Bid Bond in the amount of 5% of their Bid(Submit with bid) – Parking Lot A & B with the bid.**
- **Prior to contract execution, successful bidder must provide performance and payment bonds in the amount of 100% of the project bid.**

**Davis Bacon Act compliance is required for this project. See Contract Exhibit A – Federal Transit Administration Clauses: Davis Bacon Act - Copeland Anti-Kickback Act; See Appendix A of ITB for information regarding Davis Bacon Rates**

**This Contract requires Buy America Compliance – See Contract Exhibit A – Buy America Requirements and Required Forms (Form 14 – Buy America Certification).**

**\*\*Low bidder will be based on the Total Project, which will include the cost of the total Base Bid . However, WeGo reserves the right to forgo including the Additive Bid Alternative in the final contract negotiation.\*\***

#### **BID DEADLINE**

Bids will be accepted, via e-mail to: [wade.mcmillian@nashville.gov](mailto:wade.mcmillian@nashville.gov) until 1:00 pm , Central Time (CT), Friday, August 30, 2024. Bids received after this date and time will not be accepted.

#### **QUESTIONS/CLARIFICATION DEADLINE**

All questions, requests for clarification, and other inquiries related to this ITB must be received by [wade.mcmillian@nashville.gov](mailto:wade.mcmillian@nashville.gov) , no later than 1:00 pm CT, Monday, August 19, 2024.

#### **PRE-BID MEETING & SITE TOUR**

A pre-bid meeting will be held on Friday, August 16, 2024, at 1:00 pm CT at the 430 Myatt Drive Madison, TN 37115. All site tour will be only available upon request.

**\*Pre-Bid Meeting at 1:00 pm Procurement Conference Room or virtual \***

<https://nashville.webex.com/nashville/j.php?MTID=mf1b49e297700c8da56c0cae96549ca13>

While attendance is not mandatory, proposers are encouraged to attend and participate. The purpose of the pre-bid meeting is to address the solicitation requirements and the procurement process.

Assistance for disabled, blind, or hearing-impaired persons who wish to attend is available with prior arrangement by contacting [wade.mcmillian@nashville.gov](mailto:wade.mcmillian@nashville.gov).

If interpretations, specifications, or other changes to the solicitation are required as a result of the meeting, the Agency will post an addendum to the Procurement webpage at <https://www.wegotransit.com/doing-business/current-opportunities/>.

#### **ADDENDA REQUEST**

Bidders are not to contact other Agency personnel with any questions or clarifications in reference to this ITB. The Procurement Department will provide all official communication concerning this ITB.

To receive direct communication of all Addenda, proposers must submit an email or the form below to [wade.mcmillian@nashville.gov](mailto:wade.mcmillian@nashville.gov) by 1:00 pm CT, Monday , August 19, 2024 via email to gov to receive direct copies or notices of addenda.

**The subject matter heading of the email must read: ITB Project # 2024171 – Lot Expansion and Improvements – Request to Receive Addenda.** The body of the email must include the following information: Proposing Firm Name, Proposing Firm US Mail Address; Proposing Firm Contact Person, Name, Telephone Number, and Email Address to receive all addenda and notices. Bidders are solely responsible for assuring receipt of all addenda and have no claim against the Agency for missed receipt of Addenda.

I HAVE READ AND UNDERSTOOD THIS REQUEST FOR PROPOSALS Project # 2024171 and do herein request copies or notices of addenda. The information requested below must be received no later than 1:00 pm CT, Monday, August 19, 2024, via e-mail at [wade.mcmillian@nashville.gov](mailto:wade.mcmillian@nashville.gov).

Company Name

Phone Number

Address

Point of Contact

Email:

## TABLE OF CONTENTS

| <u>Section</u>  | <u>Page</u>  |
|---|--------------|
| <b>Federal Transit Administration Clauses<br/>Contract Exhibit A</b>                  | <b>82</b>    |
| <b>State of Tennessee Clauses<br/>Contract Exhibit</b>                                | <b>98</b>    |
| <b>Project Description</b>  | <b>1</b>     |
| <b>Special Notice to Bidders</b>  | <b>1</b>     |
| <b>Bid Bond</b>   | <b>1</b>     |
| <b>Bid Deadline</b>   | <b>2-5</b>   |
| <b>Pre-Bid Meeting and Site Tour</b>  | <b>2-5</b>   |
| <b>Addenda Request</b>  | <b>2-5</b>   |
| <b>I. Introduction</b>  | <b>5</b>     |
| Solicitation Schedule   | <b>5</b>     |
| DBE Participation Goal  | <b>6</b>     |
| <b>II. Instructions to Bidders</b>  | <b>7</b>     |
| Delivery of Bids  | <b>7</b>     |
| <b>III. Disadvantaged Business Enterprise Program</b>                                 | <b>9</b>     |
| <b>IV. Contract Documents, General Terms and Conditions,<br/>and Standard Clauses</b> | <b>16-26</b> |
| <b>V. Required Forms</b>  | <b>27</b>    |
| Bid Form  | <b>28</b>    |
| SAM Registration  | <b>35</b>    |
| DBE Forms   | <b>37</b>    |
| Bidder References   | <b>45</b>    |
| Buy America Certificate   | <b>48</b>    |
| Subcontractor Utilization Form  | <b>50</b>    |
| <b>VI. Contract</b>   | <b>50</b>    |
| Insurance   | <b>102</b>   |
| Liquidated Damages  | <b>72</b>    |
| <b>Appendix A Davis Bacon Rates</b>   | <b>107</b>   |
| <b>Appendix B Drawings and Specifications</b>   | <b>115</b>   |

---

---

## I. INTRODUCTION

---

---

### 1. SOLICITATION SCHEDULE

|  |  |
|--|--|
| <b>Pre-bid Meeting</b><br><a href="https://nashville.webex.com/nashville/j.php?MTID=mf1b49e297700c8da56c0cae96549ca13">https://nashville.webex.com/nashville/j.php?MTID=mf1b49e297700c8da56c0cae96549ca13</a>        | <b>Friday, August 16, 2024,<br/>1:00 pm CT</b> |
| <b>Submission of Request to Receive Addenda</b>  | <b>Monday, August 19, 2024,<br/>1:00 pm CT</b> |
| <b>Question/Clarification Submittal Deadline</b>   | <b>Monday, August 19, 2024,<br/>1:00 pm CT</b> |
| <b>Bid Submittal Deadline</b><br><a href="https://nashville.webex.com/nashville/j.php?MTID=mfd5f264cea994d81da6bb172dd0d2d68">https://nashville.webex.com/nashville/j.php?MTID=mfd5f264cea994d81da6bb172dd0d2d68</a> | <b>Friday, August 30, 2024,<br/>1:00 pm CT</b> |

All questions must be submitted via email to [wade.mcmillian@nashville.gov](mailto:wade.mcmillian@nashville.gov) . Any oral communication, explanation, or instruction provided will not be binding on Nashville MTA.

### 2. COST INCURRED BY BIDDERS

Nashville MTA is not liable for any costs incurred by prospective bidders in the preparation of submitting a bid in response to this ITB, in presentation of the bid or any other activities related to responding to this solicitation.

### 3. EVALUATION OF BIDS

All bids received in accordance with the requirements stated in this solicitation shall be screened initially in order to confirm the responsiveness of the written bid, including minimum qualifications, if any.

A responsive bid complies with all material aspects of the solicitation, both as to the method and timeliness of submission, and as to the substance of any resulting contract.

A responsible bidder is an individual, firm or team that exhibits adequate organization, financial condition, personnel qualifications, facilities, record of past performance, and other characteristics necessary to carry out work related to this solicitation with a high degree of quality and timeliness. Nashville MTA shall review responsive bids to determine the capacity of the bidder to provide the goods and services described in this solicitation.

### 4. BID ACCEPTED

Each bidder submits their bid with the understanding that the acceptance in writing by the Agency of the offer to furnish the services requested shall constitute a contract between the bidder and the Agency, which shall bind the bidder to furnish the services at the rates quoted, and in accordance with conditions and requirements of the Agency. A formal contract and/or purchase order will be signed between the Agency and the successful bidder.

Each bidder submits their response with the understanding that nothing in this solicitation shall be construed to require the Nashville MTA to award a contract.

Bidders must indicate that the company is prepared to enter into a contract with Nashville MTA in accordance with the terms and conditions set forth in this solicitation, any addenda, and proposed contract. Bids shall be valid for a minimum period of one hundred twenty days (120) from the date of the opening of bids.

#### **5. DISADVANTAGED BUSINESS ENTERPRISE (DBE) PARTICIPATION**

In connection with this project, Nashville MTA has established a specific goal for Disadvantaged Business Enterprise (DBE) participation of **7.5%**. Bidders are required to make good faith effort to cooperate with Nashville MTA in meeting its commitments and goal of 5% percent for goods and services for the fiscal years 2023-2026. DBE participation is encouraged either in the capacity of the prime contractor or subcontractor. Bidders are required to document their activities in the bid and selection of any subcontractor(s) to ensure that the process is nondiscriminatory. To be considered a certified DBE, the organization must be registered with the Tennessee Uniform Certification Program (TNUCP). Utilize the following website for a comprehensive list of the certified DBE's: <https://www.tdot.tn.gov/APPLICATIONS/DBEDIRECT/Search>. **See Section III - DISADVANTAGED BUSINESS ENTERPRISE PROGRAM – for more information.**

*End Section I*

---

---

## II. INSTRUCTIONS TO BIDDERS

---

---

### 1. REQUESTS FOR CLARIFICATION

All questions/requests for clarifications must be emailed to: [wade.mcmillian@nashville.gov](mailto:wade.mcmillian@nashville.gov) by 1:00 pm CT, Monday, August 19, 2024.

**Bidders must also submit any requests for changes to proposed contract terms by 1:00 pm CT, Monday, August 19, 2024. Requests for changes to proposed contract terms received after this date will only be considered if they are advantageous to Nashville MTA. No changes to contract terms will be considered after bids questioning period.**

### 2. DELIVERY OF BIDS

**Bidders must submit one (1) hard copy with original signatures and (1) one electronic copy of their bid package.**

Sealed bids will be received and publicly opened by Nashville MTA and must include ALL required forms by 1:00 pm CT, Friday, September 6, 2024, to the following address:

Wade McMillian, Procurement Administrator  
Nashville MTA  
430 Myatt Drive -- FRONT DESK  
Nashville, TN 37115

The sealed envelope, box, or appropriate package must be clearly marked with “**BID Project # 2024171 – Lot Expansion and Improvements – Project # 2024171**” on the lower left side and “**DO NOT OPEN WITH REGULAR MAIL.**” Nashville MTA will not consider bids received after the deadline. All bids will be logged, by a Procurement staff member, with the date and time of receipt.

**The electronic copy of the bid document must be submitted no later than 1:00 pm CT, Friday, September 6, 2024.** Bidders may submit their electronic copy via USB or via email to [wade.mcmillian@nashville.gov](mailto:wade.mcmillian@nashville.gov) . Bidders are advised that incoming email to Nashville MTA has a file size limit of 30MB. Bidders must ensure that any email transmission is received prior to the bid due date and time.

Bidders are solely responsible for delivery of their bid on time. Bidders who rely on overnight delivery services, local couriers, or other delivery services remain solely responsible for timely delivery of the bid and assume all risk of late delivery or no delivery. Bidders must ensure that both the hard copy and the electronic copy of the bid are delivered on time. Late bids will not be considered.

**\*\*NOTE: RESPONSES WILL BE READ PUBLICLY via WebEx\*\***

### 3. BID WITHDRAWAL

Bidders will be given permission to withdraw their bid after it has been delivered to Nashville MTA provided the bidder makes their request by e-mail, on the organization’s letterhead, twenty-four (24) hours prior to the bid due date and time. Requests pertaining to withdrawal by telephone or e-mail must be confirmed in writing by



the bidder and must reach the office of Wade McMillian , not later than one (1) hour prior to the time fixed for submission of bids. Bids which are timely withdrawn shall be returned to the bidder unopened, at bidder's expense.

#### **4. BID**

Nashville MTA will not accept bids or award any contract to any person, firm or corporation that is in arrears or is in default to Nashville MTA upon any debt or contract, has defaulted on surety or other obligation or has failed to perform faithfully any previous contract for Nashville MTA. Nashville MTA reserves the right to request subcontractor changes to any contract.

#### **5. REJECTION OR ACCEPTANCE OF BID**

The Chief Executive Officer or designee reserves the right to accept or reject any or all or any part of any bid. Any bid which is incomplete, conditional, obscure, or which contains additions not called for, or irregularities of any kind, may be cause for rejection of the bid. If there is a discrepancy between the price written and the price listed in figures, Nashville MTA acknowledges that the price written is the correct price.

Nashville MTA reserves the right to cancel this ITB in writing or postpone or extend the date and time for submitting bids at any time. Nashville MTA reserves the right to reject any or all bids, to waive any or all informalities or irregularities in the bids received, to investigate the qualifications and experience of any bidders, to reject any provisions in any bid, to modify bid contents, to obtain new bids, or to negotiate the requested services and contract terms with any bidders. Nashville MTA reserves the right to award the ITB- requested construction services in full, in part and/or a single item to one or more bidders. Nashville MTA will determine the most responsive bidder whose bid is most advantageous.

The submission of a bid shall constitute an acknowledgement that the bidder has thoroughly examined and is familiar with the bid, including the Scope of Services, the addenda if any, and has reviewed and inspected all applicable statutes, regulations, ordinances and resolutions dealing with or related to the services requested.

**Bids must indicate that the firm is prepared to enter into a contract and/or purchase order with Nashville MTA in accordance with the terms and conditions set forth in this bid, any addenda, and proposed contract. Bids shall be valid for a minimum period of one hundred twenty (120) days from the bid due date for acceptance by Nashville MTA.**

#### **6. PUBLIC RECORDS/CONFIDENTIALITY**

The bids received become the exclusive property of Nashville MTA. When a contract award is approved by Nashville MTA, all bids submitted in response to this bid shall become a matter of public record and shall be regarded as public records, with the exception of those elements of each bid that are marked as "TRADE SECRET," "CONFIDENTIAL" or "PROPRIETARY." If required by law or by an order of a court, Nashville MTA may be required to disclose such records or portions thereof, including without limitation those so marked. Bids that indiscriminately identify all or most of the bid as exempt from disclosure without justification may be found to be technically unacceptable.

#### **7. FORMS PROVIDED**

**Bidders are to submit their bids on the forms provided or copies thereof.** The bidder or an authorized representative of the firm must sign the bid. Any erasures, corrections or other changes appearing on the bid form must be initialed and dated by the person signing the form. All required forms must be submitted with the bid.

*End Section II*

---

---

### III. DISADVANTAGED BUSINESS ENTERPRISE PROGRAM

---

---

#### 3.1 Introduction

The Agency operates a federal Disadvantaged Business Enterprise (DBE) Program to ensure full and fair opportunities in contracting for businesses owned by socially and economically disadvantaged individuals. The Agency administers the program according to the regulations that apply to 49 CFR Part 26. Only firms that are certified consistent with 49 CFR Part 26 and by the Agency or Tennessee Department of Transportation Unified Certification Program (TN UCP), as identified below, will be considered certified as a Disadvantaged Business Enterprise.

This section, entitled “Disadvantaged Business Enterprise Program” is provided in an effort to assist proposers. The information contained in this section is not intended to, nor does it, supplement or amend any federal regulation. All Proposers are responsible for compliance with all applicable federal and Agency rules and requirements.

It is a requirement that all proposers providing services take all reasonable steps to ensure that DBEs have a full and fair opportunity to compete for and perform contract work without discrimination on the basis of age, race, sex, color, national origin, creed, religion, sexual orientation or disability. In order to satisfy this requirement, proposers will be expected to timely submit documentation as identified below and as shown on the Required Forms throughout the contract period if selected and cooperate with the Agency. Failure to timely submit requested documentation, cooperate with the Agency, or answer inquiries truthfully will be considered a material contract breach and may result in contract termination.

#### 3.2 Required Documents

The following documents should be submitted with the bid:

##### 1. Letter(s) of Intent – Form 6-A

Proposers should submit a Letter of Intent for each DBE whose participation the proposer is counting toward the goal. This may include first, second, third, and other lower tier subcontractors and/or suppliers. The proposer and all DBE subcontractors and/or suppliers must sign the Letter(s) of Intent. The Letter(s) of Intent should be submitted with the proposal.

All portions of the Letter(s) of Intent should be completed (including the description of work, the estimated contract amount, and the estimated percentage of DBE participation for counting and goal purposes) before the Letter(s) of Intent is signed by either the DBE or the proposer.

##### 2. DBE Goal Commitment to DBE (Participation Form) – Form 6-B

The Proposer should submit a signed DBE Goals Commitment to DBE form with the proposal. **Failure to submit and/or sign the form may render the submission non-responsive.**

##### 3. Good Faith Effort Documentation Form – Form 6-C

If Proposer is unsuccessful in meeting the required project specific DBE goal, additional documentation is required to demonstrate the efforts it made in attempt to meet the DBE goal. See section 3.7 for detailed Good Faith Effort requirements.

##### 4. DBE Utilization Form – Form 6-D

The proposer should submit a fully completed DBE Utilization Form, providing all requested

information, and calculating the total DBE percentage.

The Agency reserves the right to ask questions of the proposer, investigate and require additional information as it determines necessary in its sole discretion to ensure that the regulations and the Agency's rules are followed as it relates to DBE participation.

### **3.3 Definition of Socially and Economically Disadvantaged**

The rules that govern eligibility and certification of DBE are found generally at 49 CFR Part 26.5 and 26.61 through 26.73. These rules define a DBE as a for-profit, small business concern which is at least fifty-one percent (51%) owned and controlled by one or more socially and economically disadvantaged individuals. In the case of any publicly owned business, at least fifty-one percent (51%) of the stock must be owned by one or more socially and economically disadvantaged individuals. In addition, the personal net worth of the socially and economically disadvantaged owners of the small business concern must not exceed one million three hundred twenty thousand dollars (\$1,320,000).

As defined by 49 CFR, Part 26.5, a socially and economically disadvantaged individual is any individual who is a citizen (or lawfully admitted permanent resident) of the United States and who is –

- (1) Any individual who a recipient finds to be a socially and economically disadvantaged individual on a case-by-case basis.
- (2) Any individual in the following groups, members of which are rebuttably presumed to be socially and economically disadvantaged:
  - (i) “Black Americans” which includes persons having origins in any of the Black racial groups of Africa;
  - (ii) “Hispanic Americans” which includes persons of Mexican, Puerto Rican, Cuban, Dominican, Central or South American, or other Spanish or Portuguese culture or origin, regardless of race;
  - (iii) “Native Americans” which includes persons who are American Indians, Eskimos, Aleuts, or Native Hawaiians;
  - (iv) “Asian-Pacific Americans” which includes persons whose origins are from Japan, China, Taiwan, Korea, Burma (Myanmar), Vietnam, Laos, Cambodia (Kampuchea), Thailand, Malaysia, Indonesia, the Philippines, Brunei, Samoa, Guam, the U. S. Trust Territories of the Pacific islands (Republic of Palau), the Commonwealth of the Northern Marianas Islands, Macao, Fiji, Tonga, Kiribati, Tuvalu, Nauru, Federated States of Micronesia, or Hong Kong;
  - (v) “Subcontinent Asian Americans” which includes persons whose origins are from India, Pakistan, Bangladesh, Bhutan, the Maldives islands, Nepal or Sri Lanka;
  - (vi) Women;
  - (vii) Any additional groups whose members are designated as socially and economically disadvantaged by the SBA, at such time as the SBA designation becomes effective.

### **3.4 DBE Liaison Officer**

The DBE Liaison Officer is responsible for developing, implementing, and monitoring the DBE program on a day-to-day basis in coordination with other appropriate officials; carrying out technical assistance for a DBE; and, disseminating information on available business opportunities so that a DBE is provided an equitable opportunity to propose on Agency contracts. For questions or information related to the DBE program, contact Vince Malone, DBE Liaison Officer, at [vince.malone@nashville.gov](mailto:vince.malone@nashville.gov) or 615-880-1537.

### **3.5 DBE Certification**

The Agency certifies all of its DBEs through internal processes. The TNUCP is a cooperative of entities which are recipients of federal funds that have developed a “one-stop shop” for certification throughout the State of Tennessee of which the Agency is a certifying member. In order to be considered as meeting the DBE goal for a contract, each business wishing to participate as a DBE or a joint venture DBE, must be certified as a DBE by the Tennessee Uniform Certification Program (TNUCP) and must have current certification at the time of Qualifications submission. The link to the DBE Directory is <https://www.tdot.tn.gov/applications/dbedirect/>.

Persons or entities who consider themselves a DBE but who are not certified by the Agency, the TNUCP as a DBE, have not received affirmation from the Agency MTA or the TNUCP that their certification from another entity is consistent with and acceptable to the Agency or the TNUCP will not be considered. Unless a firm meets the criteria above by the time the responses to this solicitation are due, its participation will not be considered as meeting the DBE goal in the solicitation. Each business wishing to participate as a DBE, or a joint venture DBE must be certified at the time of submission and a current copy of the DBE’s certification must be attached to the Letter of Intent.

### **3.6 Identification of Contract Goal and Requirements**

For this contract, the overall DBE participation goal is established as **7.5%**. In order for the submission to be responsive, the proposer must either meet the goal or make good faith efforts to do so. Good faith efforts are defined in Appendix A to 49 CFR Part 26 and discussed in the following section.

If a proposer’s Commitment to DBE (Participation Form), Form 6-B, proposes a DBE percentage less than the established goal, the proposer must submit appropriate documentation justifying its submitted DBE percentage.

The Agency reserves the right to request additional documentation or information from the proposer regarding its Commitment to DBE (Participation Form), Utilization Plan, Letter of Intent, and, if applicable, any Good Faith Efforts documentation. If the Agency enters into a contract based on the proposer’s Commitment to DBE (Participation Form), Good Faith Effort and documentation, the DBE percentage accepted by the Agency will become a contractual requirement.

Proposers shall not contract with, demand, require or coerce a DBE into any agreement or into the signing of any Letter of Intent or any other document which prohibits the DBE from providing subcontracting quotations or doing business with other proposers. The DBE shall be free to provide their services to any number of proposers. To ensure that all obligations under subcontracts awarded to a DBE are met, the Agency may review the agreement between the proposer and DBE and the proposer’s DBE involvement efforts during the performance of the contract.

The proposer shall bring to the attention of the Agency any situation in which regularly scheduled progress payments are not made to a DBE. If, in the opinion of the Agency, the proposer has made significant deviations from the DBE program commitments, it shall be considered a breach of contract.

### **3.7 Good Faith Efforts and Requirements**

In order to be responsive, proposers must either meet the DBE goal or make good faith efforts to meet the goal. Proposers who do not meet the goal must establish adequate good faith efforts (GFE) by submitting documentation along with the Good Faith Efforts Documentation Form (Form 6-C). The documentation should show that the proposer took all necessary and reasonable steps to achieve the DBE goal, which could reasonably be expected to obtain sufficient DBE participation, even if the proposer was not fully successful. The Good Faith Effort form and supporting documents should conform to the good faith requirements outlined in Appendix A of 49 CFR Part 26.

The following is a list of types of actions that may be part of a proposer's efforts to obtain DBE participation and may be included as part of the GFE and documentation. This list is not intended to be a mandatory checklist, nor is it intended to be exclusive or exhaustive. Other factors or types of efforts may be relevant in appropriate cases:

- (a) Soliciting through all reasonable and available means (e.g. attendance at pre-submission meetings, advertising and/or written notices) the interest of all certified as a DBE who have the capability to perform the work of the contract. The proposer must solicit this interest within sufficient time to allow the DBE to respond to the solicitation and take appropriate steps to follow-up initial solicitations to determine interest.
- (b). Selecting portions of the work to be performed by a DBE in order to increase the likelihood that the goals of the will be achieved.
- (c). Providing any interested DBE with adequate information about the plans, specifications, and requirements of the contract in a timely manner to assist them in responding to a solicitation.
- (d) Negotiating in good faith with any interested DBE. It is the proposer's responsibility to make a portion of the work available to DBE subcontractors and suppliers and to select those portions of the work or material needs consistent with the available DBE subcontractors and suppliers, so as to facilitate DBE participation.
- (e) Not rejecting any DBE as being unqualified without sound reasons based on a thorough investigation of their capabilities.
- (f) Making efforts to assist any interested DBE in obtaining bonding, lines of credit, or insurance as required by the recipient or contractor.
- (g) Making efforts to assist any interested DBE in obtaining necessary equipment, supplies, materials, or related assistance or services.
- (h) Effectively using the services of available minority/women community organizations; minority/women contractors' groups; local, state, and Federal minority/women business assistance offices; and other organizations as allowed on a case-by-case basis to provide assistance in the recruitment and placement of any DBE.
- (i) Making efforts to identify and assist eligible firms, which are not yet certified by the Agency or the TN UCP as a DBE, to obtain certification. These types of efforts will have special weight where it appears that the relevant firms will be certified in time for the execution of the contract.

If a proposer has not met the DBE goal and submits the Good Faith Effort form and documentation, the proposer should summarize in detail all good faith efforts taken by the Proposer, including, but not limited to, the activities listed above in A through I, and supporting documentation.

While the proposer should submit documentation to support its good faith efforts at the time of submission, the Agency may ask questions of Proposer or request additional documentation after review of proposer's Good Faith Effort and any documentation. In submitting the information required under this section, the proposer understands and agrees that the determination of whether the proposer has met the DBE goal or established good faith efforts to meet the goal is a judgment call that the Agency will make.

### **3.8 Counting DBE Participation**

DBE participation shall be counted toward meeting the DBE goal as outlined in 49 CFR Part 26, especially 26.55. When the proposer completes a Letter of Intent, the Proposer must include not only the total value of the work

to be performed and/or the materials to be supplied by the DBE but also the total amount of DBE participation that should be counted toward meeting the goal.

For example, if a DBE is a regular dealer or supplier of pipe but does not install the pipe, then the proposer can generally count the dollar value spent on the pipe at 60%. This would mean that if the DBE was supplying \$100,000 of pipe then the contract amount would be \$100,000 but the total amount of DBE participation would be \$60,000 for counting and meeting the goal purposes.

If a proposer has any questions about counting, the Agency advises the proposer to consult 49 CFR Part 26. The following may be helpful in counting DBE participation and in determining which sections of Part 26.55 a proposer needs to review in more detail:

(a) When a DBE participates in a contract or subcontract, the Contractor will count only the value of the work actually performed by the DBE toward the DBE goals. In a construction contract (and other similar contracts), this will include the work performed by the DBE 's own forces and supplies purchased or equipment leased by the DBE as described below, especially (d) (but not supplies or equipment the DBE subcontractor purchases from the prime contractor or its affiliate.) The Contractor will count the entire amount of fees or commissions charged by a DBE for providing a bona fide service toward goals provided that the Agency determines the fees to be reasonable and not excessive. When a DBE subcontracts part of the work of its contract to another firm, the value of the subcontracted work may be counted toward DBE goals only if the subcontractor is itself a DBE.

(b) When a DBE performs as a participant in a joint venture, a portion of the total dollar value of the contract equal to the distinct clearly defined portion of the work of the contract that the DBE performs with its own forces count toward DBE goals.

(c) The proposer will count expenditures to a DBE contractor toward DBE goals only if the DBE is performing a commercially useful function on that contract. A DBE performs a commercially useful function when it is responsible for execution of the work of the contract or subcontract and is carrying out its responsibilities by actually performing, managing, and supervising the work involved.

To determine whether a DBE is performing a commercially useful function, the proposer will evaluate industry practices, the amount of work subcontracted, whether the amount the firm is to be paid under the contract is commensurate with work it is actually performing, and the DBE credit claimed for its performance of the work, and other relevant factors. The proposer will determine questions of commercially useful function with regard to trucking companies under 49 CFR Part 26.55 (d).

(d) The proposer will count expenditures with the DBE for materials or supplies toward DBE goal in the manner described in 49 CFR Part 26.55 (e). **Note:** Proposers should review Part 26.55(e) carefully. It is important to note that the rule counts expenditures differently based upon whether the DBE is a manufacturer as defined by the rule (normally counted at 100% percent of the cost), a regular dealer as defined by the rule (normally counted at 60% of the cost) or neither of the two (normally counted at the entire amount of fees or commissions, or fees or transportation charges, provided they are reasonable).

It is important to note that materials and supplies provided by a DBE that is not a regular dealer in those materials and supplies do not count toward meeting the goal. For example, if the DBE is a regular dealer of piping, the DBE cannot purchase office equipment and then supply that office equipment to the prime and count any portion of the cost of the office equipment toward meeting the

goal. Such conduct for DBE counting purposes is prohibited by the rules and is considered to be an impermissible and illegal pass-through.

(e) If a firm is not currently certified as a DBE, in accordance with the standards of subpart D of this part, at the time of the execution of the contract, the proposer will not count the firm's participation toward any DBE goals, except as provided for in 49 CFR Part 26.87(i).

(f) The proposer will not count the dollar value of work performed under a contract with a firm after it has ceased to be certified toward any goals except as provided in 49 CFR Part 26.87(j).

### **3.9 Prompt Payment and Retainage**

The Contractor agrees to pay each subcontractor under this prime contract for invoices submitted or normal progress payments for work completed satisfactorily or supplies provided satisfactorily pursuant to its contract and no later than fifteen (15) days from the receipt of each payment it receives from the Agency.

There is no retainage or other sums allowed to be withheld from progress payments or any other payments and any exceptions to this prompt pay/retainage provision must be requested in writing by the Contractor and approved in writing.

The Contractor will include the following paragraphs in all contracts and/or agreements related to the work under this Contract with subcontractors or suppliers and will require all its subcontractors and suppliers to include this paragraph in any contracts and/or agreements related to the work under this Contract with any other third parties and any other lower tier subcontractors or suppliers:

*"It is understood and agreed by all involved parties that payment for work completed satisfactorily, or supplies provided satisfactorily will be made to the appropriate party no later than fifteen (15) days from receipt of payment for that work or those supplies.*

*There is no retainage or other sums allowed to be withheld from progress payments or any other payments and any exceptions to this prompt pay/retainage provision must be requested in writing to the Agency and approved in writing."*

### **3.10 Termination of DBE Subcontractor**

The Contractor shall not terminate the DBE subcontractor(s) listed in the DBE Utilization Plan without the Agency's prior written consent. The Agency may provide such written consent only if the Contractor has good cause to terminate the DBE firm. Before transmitting a request to terminate, the Contractor shall give notice in writing to the DBE subcontractor of its intent to terminate and the reason for the request.

The Contractor shall give the DBE five (5) days to respond to the notice and advise of the reasons why it objects to the proposed termination. When a DBE subcontractor is terminated or fails to complete its work on the Contract for any reason, the Contractor shall make good faith efforts to find another DBE subcontractor to substitute for the original DBE and immediately notify the Agency in writing of its efforts to replace the original DBE. These good faith efforts shall be directed at finding another DBE to perform at least the same amount of work under the Contract as the DBE that was terminated, to the extent needed to meet the Contract goal commitment for this procurement. The Contractor may not terminate any DBE subcontractor and perform that work through its own forces or those of an affiliate without prior written consent of the Agency.

### **3.11 Continued Compliance**

The Agency shall monitor the Contractor's DBE compliance during the life of the Contract using an online reporting system: <https://wegotransit.dbesystem.com>. Monthly audit entries are required to report contract payments to prime and subcontractors. Each month, Contractor shall report payments received from the

Agency as well as payments made to all subcontractors. Contractors are responsible for providing accurate and complete information each month and as requested.

### **3.12 49 CFR Part 26**

The Contractor shall carry out the applicable requirements of 49 CFR Part 26 in the award and administration of the Agency's contracts. The proposer agrees to provide all its subcontractors and suppliers, and to require all its subcontractors and suppliers on this project to provide a complete copy of the **Disadvantaged Business Enterprise (DBE) Requirements** to all those who provide supplies or perform work related to this Contract and to require all those providing supplies or work to be bound by these requirements as it relates to their work related to this Contract.

*End Section III*



---

---

## IV. CONTRACT DOCUMENTS, GENERAL TERMS AND CONDITIONS, STANDARD CLAUSES

---

---

### CONTRACT DOCUMENTS

---

#### 1. CONTRACT DOCUMENTS

Any contract resulting from this bid shall include the following:

- Invitation To Bid No Project # 2024171 and all addenda
- Bidder's Offer and Guarantee
- Bid Award/Contract

The Contractor and appropriate parties of Agency will sign to execute contract.

Federal requirements apply to this procurement and any future contract. If those requirements change then the most recent requirements shall apply. The Federal Government requires that activities financed in part, with Federal funds, and performed by a third-party contractor and/or its subcontractors on behalf of the Agency must be in accordance with Federal requirements.

All subcontracts and subcontractors employed under this contract are subject to the same conditions and regulations as set forth herein unless specifically exempted.

The prime contractor shall ensure that its subcontractors at all tiers are aware of and comply with these Federal regulations. The prime contractor is liable for subcontractors' compliance failures. Failure to comply will render the prime contractor responsible for damages and/or contract termination.

### GENERAL TERMS AND CONDITIONS

---

#### 1. GENERAL REQUIREMENTS

The parties shall fully cooperate with one another and shall take any additional acts that may be necessary, appropriate, or convenient to attain the purposes of this bid and any contract entered into.

#### 2. BIDDER'S AFFIDAVITS NON-COLLUSION

The bidder guarantees that the bid submitted is not a product of collusion with any other bidders and no effort made to fix the bid price of any bidders, or to fix any overhead, profit or cost elements of any bid price. An affidavit of non-collusion form is included and must be signed and submitted with bid.

#### 3. INSURANCE REQUIREMENTS

During the term of this Contract, Contractor shall, at its sole expense, obtain and maintain in full force and effect for the duration of the Contract and any extension hereof the types and amounts of insurance identified in the **Contract, Section 17 – Insurance and Surety Bonds - and EXHIBIT E – Insurance Requirements.**

#### **4. INTEREST OF MEMBERS OF NASHVILLE MTA**

No member of the governing body of Nashville MTA, other officer, employee or agent of Nashville MTA who exercises any functions or responsibilities in connection with the carrying out of the activities, to which this Contract pertains, shall have any personal interest, direct or indirect, in this Contract.

#### **5. INTEREST OF OTHER LOCAL PUBLIC OFFICIALS AND STATE OFFICIALS**

No member of the governing body of Metro, and no other public official of such locality, who exercises any functions or responsibilities in the review or approval of the carrying out of activities to which this Contract pertains, shall have any personal interest, direct or indirect, in this Contract. No part of the proceeds shall be paid directly or indirectly to any officer or employee of the State of Tennessee as wages, compensation or gifts in exchange for acting as officer, agent, employee, subcontractor, or bidders to Nashville MTA in connection with any work contemplated or performed relative to this Contract.

#### **6. INTEREST OF MEMBERS, OR DELEGATES TO CONGRESS**

In accordance with 18 U.S.C. Section 431, no member of, or delegate to, the Congress of the United States shall be admitted to any share or part of this Contract, or to any benefit arising there from.

#### **7. INTEREST OF THE BIDDERS**

The bidder covenants that it presently has no interest and shall not acquire any interest, direct or indirect, which would conflict in any manner or degree with the performance of services required to be performed under this Contract. The bidder further covenants that no person having such interest shall be employed in the performance of this Contract.

#### **8. WORKERS COMPENSATION ACT**

The Contractor shall comply with the State Law known as the Workers' Compensation Act and shall pay into the State insurance fund the necessary premiums required by the Act to cover all employees furnishing said services to Nashville MTA, and under the control of the Contractors, and shall relieve Nashville MTA from any costs due to accidents and other liabilities mentioned in said Act.

#### **9. SOCIAL SECURITIES ACT**

The Contractor shall be and remain an independent Contractor with respect to all services performed and agrees to and does accept full and exclusive liability for payment of any and all contributions or taxes for social security, unemployment insurance, and retirement benefits or annuities imposed under any State and Federal law which are measured by the wages, salaries, or other remunerations paid to persons by the Contractor for work performed under the terms of this contract. The Contractor agrees to obey all lawful rules and regulations and to meet all lawful requirements which are now or may be issued or promulgated under laws authorized by State or Federal officials; and Contractor also agrees to indemnify and save harmless the Nashville MTA from any contributions or liability, therefore.

#### **10. EQUAL EMPLOYMENT OPPORTUNITY**

In implementing the Project/Contract, the bidder may not discriminate against any employee or applicant for employment because of race, color, creed, sex, disability, age, or national origin. The bidder agrees to take affirmative action to ensure that applicants are employed, and that employees are treated during employment,

without regard to their race, color, creed, sex, disability, age, or national origin. Such action shall include, but not be limited to, the following: employment, upgrading, demotion or transfer, recruitment or recruitment advertising, layoff or termination; rates of pay or other forms of compensation; and selection for training, including apprenticeship. The bidder shall insert the foregoing provisions (modified only to show the particular contractual relationship) in all subcontracts, except subcontracts for standard commercial supplies or raw materials.

#### **11. AUTHORITY TO ENTER CONTRACT**

The bidder has all requisite power and authority to conduct its business and to execute, deliver, and perform services specified in the bid and any Contract that may be issued. The bidder warrants that the individuals who have signed the bid have the legal right and authority to bind the bidders.

#### **12. AUTHORIZATION OF BID**

If the bid is made by an individual doing business under an assumed name, the bid shall so state. If the bid is made by a partnership, the full name and addresses of each member and the address of the partnership shall be given and the bid shall be signed by one member thereof. If the bid is made by a corporation, it shall be signed in the corporate name by an authorized officer. If the bid is made by a joint venture, the full name and address of each member of the joint venture shall be given and the bid shall be signed by each venture. Form(s) is included to be filled out and submitted with bid.

#### **13. SUBCONTRACT APPROVAL**

Bidders' subcontracts shall contain a provision making the subcontractor(s) subject to all provisions stipulated in the Contract. The bidder shall be fully responsible for all services performed by any subcontractor.

#### **14. COST/PRICE ANALYSIS**

Nashville MTA reserves the right to conduct a cost or price analysis for any purchase or service. Nashville MTA may be required to perform a cost/price analysis when competition is lacking for any purchase. Sole source procurements or procurements which result in a single bid received, will be subject to a cost/price analysis, which will include the appropriate verification of cost data, the evaluation of specific elements of costs and the projection of the data to determine the effect on bid prices. Nashville MTA may require a pre-award audit, and bidders shall be prepared to submit data relevant to the proposed work which will allow Nashville MTA to sufficiently determine that the proposed price is fair, reasonable, and in accordance with Federal, State, and local regulations. Procurements resulting in a single bid will be treated as a negotiated procurement and Nashville MTA reserves the right to negotiate with the single bidder to achieve a fair and reasonable price. If both parties cannot agree upon a negotiated price, Nashville MTA reserves the right to reject the single bid.

All contract change orders or modifications will be subject to a cost analysis.

#### **15. PRICING**

The price quoted in any bid submitted shall include all necessary costs to complete the services in accordance with the specifications. Anything omitted from such specifications, which are clearly necessary, shall be considered a portion of such cost although not directly specified or called for in the specifications. bidders should note discounts.

## 16. PROMPT PAYMENT

The Contractor agrees to pay each subcontractor for satisfactory performance of its contract no later than 15 days from receipt of each payment the Contractor receives from Nashville MTA. Any delay or postponement of payment from the above reference may occur only for good cause following written approval of Nashville MTA. This clause applies to both DBE and non-DBE subcontractors. If the Contractor determines the work to be unsatisfactory, it must notify Nashville MTA immediately, in writing, and state the reasons. Failure to comply with this requirement would be construed to be a breach of contract and subject to contract termination.

Based upon Applications for Payment submitted to Nashville MTA by the Contractor and Certificates for Payment issued by the Architect, Nashville MTA shall make progress payments on account of the Contract value to the Contractor as provided below and elsewhere in the Contract Documents.

The period covered by each Application for Payment shall be one calendar month ending on the last day of the month, or as follows:

Provided that an Application for Payment is received by the Architect not later than the 10th day of a month, Nashville MTA shall make payment of the certified amount to the Contractor not later than net thirty (30) days after receipt of the payment application. If an Application for Payment is received by the Architect after the application date fixed above, payment shall be made by Nashville MTA not later than thirty days (30) days after the Architect receives the Application for Payment.

Each Application for Payment shall be based on the most recent schedule of values submitted by the Contractor in accordance with the Contract Documents. The schedule of values shall allocate the entire Contract Sum among the various portions of the Work. The schedule of values shall be prepared in such form and supported by such data to substantiate its accuracy as the Architect may require. This schedule, unless objected to by the Architect, shall be used as a basis for reviewing the Contractor's Applications for Payment.

Applications for Payment shall show the percentage of completion of each portion of the Work as of the end of the period covered by the Application for Payment. Subject to other provisions of the Contract Documents, the amount of each progress payment shall be computed as follows:

1. Take that portion of the Contract Sum properly allocable to completed Work as determined by Multiplying the percentage completion of each portion of the Work by the share of the Contract Sum allocated to the portion of the Work in the schedule of values. Pending final determination of cost the Owner of changes on the Work, as amount not in dispute shall be included as provided in 7.3.9 of AIA Document A201 tm –2007, General Conditions of the Contracts of Construction;
2. Add the portion of the Contract sum properly allocable to material and equipment delivered and suitable stored at the site subsequent incorporation in the completed construction (or, if approved in advanced by the Owners, suitably stored off the site at a location agreed upon in writing);
3. Subtract amounts, if any, for which the Architect has withheld or nullified a Certificate for Payment as provided in Section 9.5 of AIA Documents A201-2007.

The Progress payment amount determined in accordance with the above section shall be further modified under the following circumstances:

1. Add, upon Substantial Completion of the Work, a sum sufficient to increase the total payments to the full amount of the Contract Sum, less such amounts as the Architect shall determine for incomplete Work and unsettled claims; and
2. Add, if final completion of the Work is thereafter material delayed through no fault of the Contractor, any additional amounts payable in accordance with Section 9.10.3 of AIA Document A201-207.

Except with Nashville MTA's prior approval, the Contractor shall not make advance payments to suppliers for materials or equipment which have not been delivered and stored at the site.

### **Final Payment**

Final payment, constituting the entire unpaid balance of the Contract Sum, shall be made by Nashville MTA to the Contractor when:

1. The Contractor has fully performed the Contract except for the Contractor's responsibility to correct Work as provided in Section 12.2.2 of AIA Document A201-2007, and to satisfy other requirements, if any, which extend beyond final payment; and
2. All warranties, guarantees, record drawings, operation and maintenance manuals, and all other materials have been provided by the Contractor to the Agency.
3. A final Certificate for Payment has been issued by the Architect.

Nashville MTA's final payment to the Contractor shall be made no later than 30 days after the issuance of the Architect's final Certificate for Payment, or as outlined in the Dispute Resolution section.

## **17. PROTEST**

### **A. Definitions for Purposes of the section**

The term "days" refers to working days of the Authority.

The term "interested party" means any person (a) who is an actual bidder or prospective bidder in the procurement involved, and (b) whose direct economic interest would be affected by the award of the contract or by a failure to award the contract.

Note – WeGo will notify FTA regional office when it receives a third-party contract protest on a contract with substantial FTA funds (projects over \$500,000), and keep FTA informed about the status of the protest.

B. The Agency will hear and consider a bona fide protest regarding its procurement actions. It is anticipated that the majority of protests will be evaluated and finally decided by the Authority. Accordingly, the Authority intends to provide a thorough review of all bona fide proposal protests. The Authority's primary concern, however, is the timely procurement of needed capital equipment, supplies or services. It does not intend to allow the filing of protests to unnecessarily delay the procurement process, especially if the protest involved is vexatious or frivolous in nature.

Notwithstanding the availability of these protest procedures, any interested party is encouraged to exhaust all methods described in this section of resolving an issue before filing a formal protest with the Authority. In its

consideration of a protest, the Authority reserves the right to give due consideration to the good faith efforts of the protestor to resolve the issue involved through informal methods.

#### C. Submission of Protest

Any interested party may file a protest with the Authority on the basis that the Authority has failed to comply with applicable Federal or State Regulations or with the Authority's Procurement Process. The protest must be filed in accordance with the timing requirements set forth in subsection D. "Types of Protests and Timing" of this section, and must include: **The name, phone number, e-mail and address of the protestor.**

The proposal and proposed contract number of the proposal.

A statement of grounds for the protest, a statement as to what relief is requested, and the Federal or State law or Authority Process alleged to have been violated. This statement should be accompanied by any supporting documentation the protesting party desires the Authority to consider in making its decision. Protest(s) should be submitted to:

Kim Hereford  
Manager of Procurement  
430 Myatt Drive  
Nashville, TN 37115  
[kim.hereford@nashville.gov](mailto:kim.hereford@nashville.gov)

#### D. Types of Protests and Timing

The requirement for timely filing of protest with the Authority will depend upon the type of protests involved. The Authority will consider the following three types of protest by interested parties:

##### 1. Protest regarding Proposal

Any protest regarding the proposal must be filed no later than five (5) business days before proposal due date. Any protest filed after that date regarding the proposal will not be considered by the Authority.

This type of protest would include any claim that the proposal contained exclusionary or discriminatory specification, any challenge to the basis of award, or any claim that the proposal documents or the proposal process violated applicable Federal or State law, or that the Authority failed to follow its procurement process in the proposal solicitation.

##### 2. Protests regarding Requirements and Responsiveness

Any protest regarding the requirements and responsiveness of the proposal by the Authority must be filed with Authority no later than five (5) business days after receipt of letter of notification of non-responsiveness. Any protest filed after such date regarding the requirements and responsiveness will not be considered by the Authority.

This type of protest would include any challenge to determinations by the Authority of the responsiveness of or the responsibility of a bidder, or any claim that the requirements and responsiveness of the proposal violated Federal or State law or the Authority's procurement process.

### 3. Protest Regarding Receipt of Non-Award Notification

Any protest regarding the award of the contract must be filed no later than five (5) business days after receipt of Non-Award Notification. Any protest regarding the award of the contract filed after that date will not be considered by the Authority.

This type of protest will only be entertained by the Authority if the protestor is able to demonstrate that the party awarded the contract fraudulently represented itself as a responsible bidder or that the Authority violated Federal or State regulations or its procurement process in the award of the contract.

#### E. Authority Response

The Authority will notify the protestor five business days after receipt of a protest and may, where appropriate, request additional information from the protestor. The Authority may, at its discretion, meet with protestor to review the matters raised by the protest. The Authority's consideration of the particular types of protests will, except as otherwise stated in subsection 2. "Decisions by Authority" of this section E. "Authority Response" in accordance with the following provisions:

##### 1. Types of Protests

###### a. Protest regarding the proposal

Upon receipt of a timely filed protest regarding the proposal, the Authority will postpone the opening until resolution of the protest. No additional proposals will be accepted during the period of postponement.

If the protest regarding the proposal involves a claim of unduly restrictive or exclusionary specifications, the Authority will, in evaluation of the protest, consider both the specific need of the Authority for the feature or item challenged and any effects on competition of including the specifications regarding that feature or item. If the Authority determines that such feature or item was included in the specification in order to meet justified and valid transit needs of the Authority and was not unduly restrictive of competition or designed to exclude a particular competitor, then the Authority will have grounds to deny the protest.

###### b. Protest regarding requirement and responsiveness

Upon receipt of a timely filed protest regarding the requirements responsiveness, the Authority will suspend its evaluation of all proposals submitted until resolution of the protest, if the Authority determines that the protestor has established that there are reasonable doubts regarding the responsiveness of a proposal or the responsibility of a bidder or regarding the Authority's compliance with Federal or State Regulations or its procurement process.

###### c. Protests after non-award notification

Upon receipt of a timely filed protest regarding the non-award notification, the Authority will not proceed with contract, if necessary, until the resolution of the protest if the Authority determines that the protestor has established a prima facie case that the contract was awarded fraudulently or in violation of that Federal or State Regulations or the Authority's procurement process.

## 2. Decisions by Authority

As indicated above, in most instances the Authority will suspend the procurement process upon receipt of a bona fide protest. However, the Authority reserves the right, notwithstanding the pendency of a protest, to proceed with the appropriate action in the procurement process or under the contract in the following cases:

- A. where the item to be procured is urgently required.
- B. where the Authority determines that the protest was vexatious or frivolous; and
- C. where delivery or performance will be unduly delayed or other undue harm will occur, by failure to make the award promptly.

After reviewing the protest submitted under this section, the Authority will issue a written decision of the basis of the information provided by the protestor, the results of any meetings with protestor, and the Authority's own investigation. If the protest is upheld, the Authority will take appropriate action to correct the procurement process and protect the rights of the protestor, revised evaluation of Proposal or Authority determinations, or termination of the contract. If the protest is denied, the Authority will lift any suspension imposed and proceed with the procurement process. If the protestor is not satisfied with the response of the Director, the protestor may appeal in writing to the Chief Executive Officer or the CEO's designee ("CEO"), within five (5) business days from the date of the Director's response. The CEO, in his or her sole discretion, shall determine if the protest has been given fair and reasonable consideration by the Director, or if additional information is needed or consideration is warranted. The CEO will provide a response within ten (10) business days after receipt of the appeal. The CEO's decision is final and no further action on the protest shall be taken by Nashville MTA. By written notice to all parties, the Director or CEO may extend the time provided for each step of the protest procedures, extend the date of notice of award, or postpone the award of a contract if deemed appropriate for protest resolution.

## F. FTA Protest Procedure

Note – WeGo will notify FTA regional office when it receives a third-party contract protest on a contract with substantial FTA funds (projects over \$500,000), and keep FTA informed about the status of the protest. A protestor must exhaust all administrative remedies with the Authority before pursuing a protest with FTA. An appeal to FTA must be on the grounds of a federal concern. Protesters must raise any federal matters arising out of the agency's award of a third-party contract within five (5) business days of the agency's final decision of the bid protest as set forth in the Best Business Practice Manual section 4.9.

## 18. ADDITIONAL SERVICES REQUEST

The Authority reserves the right to request Additional Services under this bid that may not be specifically identified within. Bidders are encouraged to identify and provide supporting statements for any other area(s) of services not listed in the Scope that may be related to Additional Services and the work of The Authority.

## 19. PROPOSED CONTRACT ALTERATIONS

No alterations or variables in the terms of the bid and /or of the Proposed Contract shall be valid or binding upon Nashville MTA unless authorized in writing by Nashville MTA.

## 20. ASSIGNABILITY

Any public agency (i.e., city, district, public agency, municipality, and other political subdivision or any FTA-funded entity) shall have the option of participating in any award made as a result of a bid and/or contract at



the same prices, terms and conditions. Nashville MTA reserves the right to assign any or all portions of Services awarded under this bid and/or contract. This assignment, should it occur, shall be agreed to by Nashville MTA and the Contractor. Once assigned, each agency will enter into its own contract and be solely responsible to the Contractor for obligations to the service assigned. Nashville MTA's right of assignment will remain in force over the contract period or until completion of the contract including options, whichever occurs first. Nashville MTA shall incur no financial responsibility in connection with contracts issued by another public agency. The public agency shall accept sole responsibility for placing service and payments to the Contractor.

## **21. PUBLICATION AND MEDIA RESTRICTIONS**

The Contractor shall not publish or reproduce subject data in whole or in part, or in any manner or form, without the advance written consent of Nashville MTA, unless the Nashville MTA has released or approved the release of that data to the public.

## **22. GRATUITIES AND KICKBACKS**

It shall be a breach of ethical standards for any person to offer, give or agree to give any employee or former employee, or for any employee or former employee to solicit, demand, accept or agree to accept from another person, a gratuity or an offer of employment in connection with any decision, approval, disapproval, recommendation, preparation of any part of a program requirement or a purchase request, influencing the content of any specification or procurement standard, rendering of advice, investigation, auditing or in any other advisory capacity in any proceeding or application, request for ruling, determination, claim or controversy or other particular matter, pertaining to any program requirement of a contract or subcontract or to any bid or bid therefore. It shall be a breach of ethical standards for any payment, gratuity or offer of employment to be made by or on behalf of a subcontractor under a contract to the prime contractor or higher tier subcontractor or a person associated therewith, as an inducement for the award of a subcontract or order. Breach of the provisions of this paragraph is, in addition to a breach of this contract, a breach of ethical standards which may result in civil or criminal sanction and/or debarment or suspension from being a contractor or subcontractor under Nashville MTA contracts.

## **STANDARD CLAUSES**

---

To the extent not inconsistent with foregoing Federal requirements, this contract shall also include those standard clauses attached hereto, and shall comply with the recipient's Procurement Guidelines, available upon request from the recipient.

The following requirements are not federal clauses.

### **1. FULL AND OPEN COMPETITION**

In accordance with 49 U.S.C. § 5325(a) all procurement transactions shall be conducted in a manner that provides full and open competition.

### **2. PROHIBITION AGAINST EXCLUSIONARY OR DISCRIMINATORY SPECIFICATIONS**

Apart from inconsistent requirements imposed by Federal statute or regulations, the Contractor shall comply with the requirements of 49 USC 5323(h)(2) by refraining from using any FTA assistance to support procurements using exclusionary or discriminatory specifications.

### **3. INELIGIBLE CONTRACTORS AND SUBCONTRACTORS**

Any name appearing upon the Comptroller General's list of ineligible contractors for federally-assisted contracts shall be ineligible to act as a subcontractor for contractor pursuant to this contract. If contractor is on the Comptroller General's list of ineligible contractors for federally financed or assisted construction, the recipient shall cancel, terminate, or suspend this contract.

### **4. COMPLIANCE WITH FEDERAL REGULATIONS**

Any contract entered pursuant to this bid shall contain the following provisions: All USDOT-required contractual provisions, as set forth in FTA Circular 4220.1F, are incorporated by reference. Anything to the contrary herein notwithstanding, FTA mandated terms shall control in the event of a conflict with other provisions contained in this Agreement. Contractor shall not perform any act, fail to perform any act, or refuse to comply with any grantee request that would cause the recipient to be in violation of FTA terms and conditions. Contractor shall comply with all applicable FTA regulations, policies, procedures and directives, including, without limitation, those listed directly or incorporated by reference in the Master Agreement between the recipient and FTA, as may be amended or promulgated from time to time during the term of this contract. Contractor's failure to so comply shall constitute a material breach of this contract.

### **5. REAL PROPERTY**

Any contract entered into shall contain the following provisions: Contractor shall at all times comply with all applicable statutes and USDOT regulations, policies, procedures and directives governing the acquisition, use and disposal of real property, including, but not limited to, 29 CFR 18.31, 49 CFR 24

Subpart B, FTA Circular 5010.1D, and FTA Master Agreement, as they may be amended or promulgated during the term of this contract. Contractor's failure to so comply shall constitute a material breach of this contract.

### **6. ACCESS TO SERVICES FOR PERSONS WITH LIMITED ENGLISH PROFICIENCY**

To the extent applicable and except to the extent that FTA determines otherwise in writing, the Recipient agrees to comply with the policies of Executive Order No. 13166, "Improving Access to Services for Persons with Limited English Proficiency," 42 U.S.C. § 2000d 1 note, and with the provisions of U.S. DOT Notice, "DOT Guidance to Recipients on Special Language Services to Limited English Proficient (LEP) Beneficiaries," 70 Fed. Reg. 74087, December 14, 2005.

### **7. ENVIRONMENTAL JUSTICE**

The Recipient agrees to comply with the policies of Executive Order No. 12898, "Federal Actions to Address Environmental Justice in Minority Populations and Low Income Populations," 42 U.S.C. § 4321 note, except to the extent that the Federal Government determines otherwise in writing.

### **8. ENVIRONMENTAL PROTECTIONS**

Compliance is required with any applicable Federal laws imposing environmental and resource conservation requirements for the project. Some, but not all, of the major Federal laws that may affect the project include: the National Environmental Policy Act of 1969; the Clean Air Act; the Resource Conservation and Recovery Act; the comprehensive Environmental response, Compensation and Liability Act; as well as environmental

provisions with Title 23 U.S.C., and 49 U.C. chapter

53. The U.S. EPA, FHWA and other federal agencies may issue other federal regulations and directives that may affect the project. Compliance is required with any applicable Federal laws and regulations in effect now or that become effective in the future.

## **9. GEOGRAPHIC INFORMATION AND RELATED SPATIAL DATA**

Any project activities involving spatial data or geographic information systems activities financed with Federal assistance are required to be consistent with the National Spatial Data Infrastructure promulgated by the Federal Geographic Data Committee, except to the extent that FTA determines otherwise in writing.

## **10. FEDERAL SINGLE AUDIT REQUIREMENTS FOR STATE ADMINISTERED FEDERALLY AID FUNDED PROJECTS ONLY**

Non-Federal entities that expend \$500,000 or more in a year in Federal awards from all sources are required to comply with the Federal Single Audit Act provisions contained in U.S. Office of Management and Budget (OMB) Circular No. A 133, Audits of States, Local Governments, and Non-Profit Organizations. Non-Federal entities that expend Federal awards from a single source may provide a program specific audit, as defined in the Circular. Non-Federal entities that expend less than \$500,000 in a year in Federal awards from all sources are exempt from Federal audit requirements for that year, except as noted in '3052.215(a), but records must be available for review or audit by appropriate officials of the Federal and State agencies.

## **11. CATALOG OF FEDERAL DOMESTIC ASSISTANCE (CFDA) IDENTIFICATION NUMBER**

The municipal project sponsor is required to identify in its accounts all Federal awards received and expended, and the Federal programs under which they were received. Federal program and award identification shall include, as applicable, the CFDA title and number, award number and year, name of the Federal agency, and name of the pass-through entity.

## **12. CFDA NUMBER FOR THE FEDERAL TRANSPORTATION ADMINISTRATION**

A Recipient covered by the Single Audit Act Amendments of 1996 and OMB Circular A-133, "Audits of States, Local Governments, and Non-Profit Organizations," agrees to separately identify the expenditures for Federal awards under the Recovery Act on the Schedule of Expenditures of Federal Awards (SEFA) and the Data Collection Form (SF-SAC) required by OMB Circular A-133. The Recipient agrees to accomplish this by identifying expenditures for Federal awards made under Recovery Act separately on the SEFA, and as separate rows under Item 9 of Part III on the SF-SAC by CFDA number, and inclusion of the prefix "ARRA" in identifying the name of the Federal program on the SEFA and as the first characters in Item 9d of Part III on the SF-SAC.

*End of Section IV*

---



---

**V. REQUIRED FORMS**

---



---

Bidders are to complete and submit the forms and information listed below. ***If a form is not applicable to your organization, please indicate not applicable and SUBMIT.***

\*Bid Forms, Licensing and Permits

|                                      |                             |  |                                |
|--------------------------------------|-----------------------------|--|--------------------------------|
| Bid Form and Bid Bond                | DBE Letter of Intent        | Certification Of Restrictions On Lobbying          | Notice to Contractor           |
| Acknowledgment of Addenda            | DBE Participation Statement | Certification of Debarment and Suspension Primary  | Buy America Certification      |
| Affidavit of Non-Collusion           | DBE Good Faith Effort       | Certification Debarment and Suspension, Lower Tier | Subcontractor Utilization Plan |
| Bidders Certification of Eligibility | DBE Utilization Plan        | References   | TN Contractor License(s)       |
| Compliance with Specifications       | Certificate of Authority    | Affidavits   | Insurance Certificates         |

\*All forms may not apply but must be submitted and indicate not applicable\*

**ACCEPTANCE OF THE PROPOSED CONTRACT TERMS AND CONDITIONS**

Indicate any exceptions to the scope of services, general terms and conditions or other requirements listed in the Proposed Contract.

- Overall quality of response and compliance to requirements and acceptance.
  1. Signature is not required on the Proposed Contract included in the bid; however, bidders requesting any changes and exceptions to the contract **must** submit their request to the close of the bid questioning period. Requests changes received after this date WILL NOT be considered. Nashville MTA reserves the right to make changes to the Proposed Contract.

## REQUIRED FORMS

---

### FORM 1 — BID FORM

TO: Nashville MTA  
[Wade.mcmillian@nashville.gov](mailto:Wade.mcmillian@nashville.gov)

BID FOR: ITB Project # 2024171  
**Lot Expansion and Improvements**  
**430 Myatt Drive Madison TN 37115**

#### 1. BIDDER REPRESENTATIONS

- A. Bidder is licensed by the State of Tennessee as required for Work of Contract. Bidder and all workers, employees, and subcontractors the Bidder intends to use in performing the Work of Contract are skilled and experienced in the types of construction required by the Contract Documents.
- B. Bidder has familiarized itself with the nature and extent of Contract Documents, Work, site, locality, and all local conditions and laws and regulations that may affect cost, progress, or performance of the Work.
- C. Bidder has given the Agency written notice of all conflicts, errors, or discrepancies discovered by the Bidder in the Contract Documents and the written resolution thereof by the Agency or Agency's assignee is acceptable.
- D. Bidder accepts the drawings and specifications as sufficiently complete for the purpose of performing the Work of Contract.
- E. Bid prices are based solely upon the Contract Documents and Addenda, and not upon any other representations.
- F. Neither Bidder nor any of Bidder's employees, agents, sub-bidders, or intended suppliers or subcontractors have relied upon any verbal representations from the Agency, the Architect, or their consultants in determining the bid prices.
- G. This Bid is genuine and not made in the interest of or on behalf of any undisclosed entity, and is not submitted in conformity with any agreement or rules of any group, association, organization, or corporation; Bidder has not directly or indirectly induced or solicited any other Bidder to submit a false or sham Bid; Bidder has not solicited or induced any entity to refrain from bidding; and Bidder has not sought by collusion to obtain for itself any advantage over any other Bidder or over the Agency.

The undersigned Bidder hereby declares and represents that she/he; a) has carefully examined and understands the Bid Documents, b) has not received, relied on, or based his Bid on any verbal instructions contrary to the Bid Documents or any addenda, c) has personally inspected and is familiar with the project site, and hereby proposes to provide all labor, materials, tools, appliances and facilities as required to perform, in a workmanlike manner, all work and services for the completion of the referenced project, all in strict accordance with the Bid Documents.

\_\_\_\_\_ Bidder's Initials

**2. CERTIFICATIONS AND BASE BID PRICES**

Base Bid, Single-Prime (All Trades) Contract: The undersigned Bidder, having carefully examined the Procurement and Contracting Requirements, Conditions of the Contract, Drawings, Specifications, and all subsequent Addenda, having visited the site, and being familiar with all conditions and requirements of the Work, hereby agrees to supply all material, labor, equipment and services, including all scheduled allowances, necessary to complete the construction of the above-named project, according to the requirements of the ITB, for the **BID – Parking Lot A & B** stipulated sum of:

Dollars (\$ \_\_\_\_\_)

In Words: ( \_\_\_\_\_ )

Bidder shall provide breakout pricing for the following items as included in the **Base Bid – Parking Lot A & B** stipulated sum listed above:

**\*BIDDERS MUST SUBMIT THEIR BREAKOUT PRICE ON THE PROVIDED EXCEL FORM\***

|  |   |           |   |                                |       |           |            |
|--|---|-----------|---|--------------------------------|-------|-----------|------------|
| <b>MYATT PARKING LOTS REHABILITATION - PARKING LOT A &amp; B</b>   |   |           |   | <b>WeGo Project No.:</b> _____ |       |           |            |
| <b>Contractor Name:</b> _____  |   |           |   | <b>Date:</b> _____             |       |           |            |
| <b>FOOTNOTES</b>   |   |           |   |                                |       |           |            |
| 1  | ITEM INCLUDES THE REMOVAL OF EXISTING TREE AT LANDSCAPE STRIP TO A DEPTH OF 2 FEET BELOW EXISTING GROUND  |           |   |                                |       |           |            |
| 2  | INCLUDES THE REMOVAL OF 30 LF OF CHAINLINK FENCE TO NEAREST POST FOR DRIVEWAY CONSTRUCTION & CAPPING OF EXISTING STORM PIPE ON LANDSCAPE STRIP INFILL |           |   |                                |       |           |            |
| 3  | COST FOR THIS BID ITEM INCLUDES ALL THE EROSION CONTROL ELEMENTS SHOWN ON THE PLANS.  |           |   |                                |       |           |            |
| 4  | INCLUDES THE COST OF LABOR AND MATERIALS USED FOR CRACK SEALING PRIOR TO PLACEMENT OF SEAL COAT   |           |   |                                |       |           |            |
| 5  | INCLUDES ALL REINFORCEMENT AS SHOWN ON DETAIL AND POLYSLICK BUS CURB RUB RAIL   |           |   |                                |       |           |            |
| 6  | ITEM INCLUDES REMOVAL OF WHEEL STOPS DURING COLD PLANING AND RESETTNG WHEEL STOPS.  |           |   |                                |       |           |            |
| 7  | ALL FITTINGS ARE INCLUDED IN THE COST PER L.F.  |           |   |                                |       |           |            |
| Item No.   | Footnote  | Item No.  | ITEM DESCRIPTION                                      | Estimated Quantity             | UNITS | COST/UNIT | TOTAL COST |
| 1  |   | 105-01    | CONSTRUCTION STAKES, LINES AND GRADES                 | 1                              | LS    |           |            |
| 2  | 1   | 201-01    | CLEARING AND GRUBBING                                 | 1                              | LS    |           |            |
| 3  | 2   | 202-01    | REMOVAL OF STRUCTURES AND OBSTRUCTIONS                | 1                              | LS    |           |            |
| 4  |   | 202-03    | REMOVAL OF RIGID PAVEMENT, SIDEWALK, ETC.             | 100                            | SY    |           |            |
| 5  |   | 202-08.10 | REMOVAL OF CURB (6" SLOPING DETACHED CONCRETE CURB)   | 852                            | LF    |           |            |
| 6  |   | 203-01    | ROAD & DRAINAGE EXCAVATION (UNCLASSIFIED)             | 992                            | CY    |           |            |
| 7  | 3   | 209-99.91 | EROSION CONTROL                                       | 1                              | LS    |           |            |
| 8  |   | 303-01.08 | MINERAL AGGREGATE, TYPE A BASE, GRADING D GRAVEL      | 1,101                          | TON   |           |            |
| 9  |   | 307-01.01 | ASPHALT CONCRETE MIX (PG64-22) (BPMB-HM) GRADING A    | 189                            | TON   |           |            |
| 10   |   | 307-01.08 | ASPHALT CONCRETE MIX (PG64-22) (BPMB-HM) GRADING B-M2 | 817                            | TON   |           |            |
| 11   | 4   | 405-02.03 | RUBBERIZED ASPHALT FOR SEAL COAT                      | 15                             | TON   |           |            |
| 12   |   | 407-20.05 | SAW CUTTING ASPHALT PAVEMENT                          | 1,746                          | LF    |           |            |
| 13   |   | 411-01.10 | ACS MIX(PG64-22) GRADING D                            | 764                            | TON   |           |            |
| 14   |   | 415-01.01 | COLD PLANING BITUMINOUS PAVEMENT                      | 940                            | TON   |           |            |
| 15   |   | 501-01.02 | PORTLAND CEMENT CONCRETE PAVEMENT (PLAIN) 6"          | 839                            | SY    |           |            |
| 16   | 5   | 604-03.07 | CLASS A CONCRETE (BUS PLATFORM)                       | 18                             | CY    |           |            |
| 17   | 6   | 702-10.03 | RESET WHEEL STOP                                      | 24                             | EACH  |           |            |
| 18   |   | 708-02.02 | MARKERS (FOR CDL COURSE)                              | 32                             | EACH  |           |            |
| 19   | 7   | 714-03.01 | DIRECT BURIAL CONDUIT (2" PVC, SCHEDULE 40)           | 730                            | LF    |           |            |
| 20   |   | 716-05.08 | PAINTED PAVEMENT MARKING (PARKING LINE)               | 4,911                          | LF    |           |            |
| 21   |   | 716-05.21 | PAINTED PAVEMENT MARKING (4" DOTTED LINE)             | 928                            | LF    |           |            |
| 22   |   | 717-01    | MOBILIZATION  | 1                              | LS    |           |            |
| 23   |   | 790-43.66 | SECONDARY PULLBOX (12 IN BY 24 IN - TRAFFIC RATED)    | 2                              | EACH  |           |            |
| 24   |   | 795-05.99 | FLOWABLE FILL (TRENCH PLUGS)                          | 13                             | CY    |           |            |
| <b>TOTAL BID \$:</b>   |   |           |   |                                |       | _____     |            |
| <b>Estimated Completion Days From Notice to Proceed:</b>   |   |           |   |                                |       | _____     |            |
| <b>NOTE:</b>   |   |           |   |                                |       |           |            |
| In the event the product of a unit price and an estimated quantity do not equal the extended amount stated, the unit price will govern, and the correct product of the unit price and the estimated quantity shall be deemed to be the amount bid. |   |           |   |                                |       |           |            |

The above **Base Bid – Parking Lot A & B** prices shall include all labor, materials, bailing, shoring, removal, overhead, profit, insurance, and incidentals required to complete the Work.

The Contractor hereby agrees to supply all material, labor, equipment, and services, including all scheduled allowances, necessary to complete the construction of the above-named project, according to the requirements of the ITB, for the **PROJECT** stipulated sum of:

Dollars (\$ \_\_\_\_\_)

In Words: ( \_\_\_\_\_ )

**3. TIME OF COMPLETION**

The undersigned Bidder agrees that the time of completion for the Project is sixty (60) days for base bid and thirty (30) additional days for additive alternative bid from the date specified in a written Notice to Proceed (NTP) to be issued after contract execution.

**4. CONTRACTOR'S LICENSE**

The undersigned bidder further states that it is a duly licensed contractor, for the type of work proposed, in the State of Tennessee, and that all fees, permits, insurances, etc., pursuant to submitting this proposal have been paid in full and are included in the lump sum price.

**Name of Bidder:** \_\_\_\_\_

**Authorized Signature & Date:** \_\_\_\_\_

**Print Name and Title of Authorized Signatory:** \_\_\_\_\_

**Telephone of Authorized Signatory Of Bidder:** \_\_\_\_\_

**Email of Authorized Signatory Of Bidder:** \_\_\_\_\_

**Address of Bidder:** \_\_\_\_\_

\_\_\_\_\_

**Tennessee Contractor License Number:** \_\_\_\_\_



**FORM 2**

**ACKNOWLEDGMENT OF ADDENDA**

The undersigned acknowledges receipt of the following addenda to the Bid documents: (If none received, write none)

ADDENDUM NUMBER: \_\_\_\_\_ DATED: \_\_\_\_\_

ADDENDUM NUMBER: \_\_\_\_\_ DATED: \_\_\_\_\_

ADDENDUM NUMBER: \_\_\_\_\_ DATED: \_\_\_\_\_

ADDENDUM NUMBER: \_\_\_\_\_ DATED: \_\_\_\_\_

ADDENDUM NUMBER: \_\_\_\_\_ DATED: \_\_\_\_\_

ADDENDUM NUMBER: \_\_\_\_\_ DATED: \_\_\_\_\_

ADDENDUM NUMBER: \_\_\_\_\_ DATED: \_\_\_\_\_

ADDENDUM NUMBER: \_\_\_\_\_ DATED: \_\_\_\_\_

ADDENDUM NUMBER: \_\_\_\_\_ DATED: \_\_\_\_\_

ADDENDUM NUMBER: \_\_\_\_\_ DATED: \_\_\_\_\_

**NOTE:** Failure to acknowledge receipt of all addenda may cause the Bid to be considered non-responsive to the Bid. Acknowledged receipt of each addendum must be clearly established and included with the Bid.

\_\_\_\_\_  
Company

\_\_\_\_\_  
Authorized Signature /Date

\_\_\_\_\_  
Name Printed

\_\_\_\_\_  
Title

**FORM 3**

**AFFIDAVIT OF NON-COLLUSION**

Affidavit and information required for Contractor:

I hereby swear, or affirm, under the penalty for perjury:

(1) That I am the Contractor (if the Contractor is an individual), a partner in the Bid (if the Contractor is a partnership), or an officer or employee of the proposing corporation with the authority to sign on its behalf (if Contractor is a corporation).

(2) That the attached Bid or Bids or any subsequently submitted best and final offer have been arrived at by the Contractor independently and have been submitted without collusion with, and without any agreement, understanding, or planned course of action with, and other vendor of materials, supplies, equipment, or services described in the Invitation To Bid, designed to limit independent proposing or competition.

(3) That the contents of the Bid have not been communicated by the Contractor, or its employees, or agents, to any person not an employee, or agent of the Contractor or its surety on any bond furnished with the Bid; and

(4) That I have fully informed myself regarding the accuracy of the statements made in this affidavit.

\_\_\_\_\_  
Company

\_\_\_\_\_  
Authorized Signature /Date

\_\_\_\_\_  
Name Printed

\_\_\_\_\_  
Title

Subscribed and sworn to before me the \_\_\_\_\_ day of \_\_\_\_\_, 20\_\_\_\_.

\_\_\_\_\_  
Notary Public

My commission expires: \_\_\_\_\_

**FORM 4**

**CONTRACTOR'S CERTIFICATION OF ELIGIBILITY**

The \_\_\_\_\_ (Name of Contractor) hereby certifies that (Check appropriate box)  is or  is not included on the United States Comptroller General's "Consolidated List of Persons or Firms Currently Debarred for Violation of Various Public Contracts Incorporation Labor Standards Provision"

\_\_\_\_\_  
Company

\_\_\_\_\_  
Authorized Signature /Date

\_\_\_\_\_  
Name Printed

\_\_\_\_\_  
Title

\_\_\_\_\_  
SAM Number

\_\_\_\_\_  
DUNS Number

NOTE: The System for Award Management (SAM) is an official website of the U.S. government.

There is no cost to use SAM. You can use this site for FREE to:

- Register to do business with the U.S. government
- Update or renew your entity registration
- Check status of an entity registration
- Search for entity registration and exclusion records

<https://www.sam.gov>

Subscribed and sworn to before me the \_\_\_\_\_ day of \_\_\_\_\_, 20\_\_\_\_.

\_\_\_\_\_  
Notary Public

My commission expires: \_\_\_\_\_

**FORM 5**

**COMPLIANCE WITH SPECIFICATIONS**

In submitting a Bid the Contractor is sufficiently informed in all matters affecting the ITB, and that the Contractor has checked the Bid for errors and omissions and hereby states that they will comply with the specifications in all areas including approved equals and addenda that were granted by the Nashville MTA.

\_\_\_\_\_  
Company

\_\_\_\_\_  
Authorized Signature /Date

\_\_\_\_\_  
Name Printed

\_\_\_\_\_  
Title

Subscribed and sworn to before me this \_\_\_\_\_ day of \_\_\_\_\_, 20\_\_.

\_\_\_\_\_  
Notary Public

My commission expires \_\_\_\_\_

**FORM 6 – A**

**DISADVANTAGED BUSINESS ENTERPRISE LETTER OF INTENT**

Submit one form for each DBE Subcontractor and/or supplier. If the DBE is a 2<sup>nd</sup>, 3<sup>rd</sup>, or lower-tier subcontractor, this form must also be signed by the Subcontractor that is utilizing the DBE.

**BIDDER:**

Name of Firm: \_\_\_\_\_

Address: \_\_\_\_\_

City: \_\_\_\_\_ State: \_\_\_\_\_ Zip: \_\_\_\_\_

Telephone: \_\_\_\_\_

**DBE:**

Name of Firm: \_\_\_\_\_

Address: \_\_\_\_\_

City: \_\_\_\_\_ State: \_\_\_\_\_ Zip: \_\_\_\_\_

Telephone: \_\_\_\_\_

**Description of work to be performed by DBE:**

\_\_\_\_\_  
\_\_\_\_\_  
\_\_\_\_\_

**The Bidder is committed to utilizing the above-named DBE for the work described above. The estimated dollar value of this work is \$ \_\_\_\_\_, which is \_\_\_\_% the proposed contract value.**

**AFFIRMATION**

The above-named DBE affirms that it will perform the portion of the contract for the estimated dollar value as stated above.

By: \_\_\_\_\_

|  |      |      |
|--|------|------|
| Signature of DBE Subcontractor and Title | Date | Name |
|--|------|------|

By: \_\_\_\_\_

|   |      |      |
|---|------|------|
| Signature of Subcontractor (if utilizing the DBE) and Title | Date | Name |
|---|------|------|

By: \_\_\_\_\_

|                               |      |      |
|-------------------------------|------|------|
| Signature of Bidder and Title | Date | Name |
|-------------------------------|------|------|

**FORM 6 – B**

**DBE GOALS – COMMITMENT TO DBE (DBE PARTICIPATION FORM)**

**Acknowledgement:** Solicitation Number: \_\_\_\_\_ has a minimum DBE participation goal of \_\_\_\_%.

The undersigned has satisfied the requirements of the of the bid/proposal’s DBE goal in the following manner (please complete the appropriate spaces):

1.  **Self-Performance:** The bidder, a certified DBE firm, is committed to **meeting or exceeding** the DBE goal through self-performance.
2.  **Self-Performance & Percentage Participation:** The bidder, a certified DBE firm, is committed to **meeting or exceeding** the DBE goal, with a minimum of \_\_\_\_\_% self-performance and a minimum of \_\_\_\_% DBE subcontracting participation on this contract.
3.  **Percentage Participation:** The bidder is committed to **meeting or exceeding** the DBE goal, with a minimum of \_\_\_\_% DBE subcontracting participation on this contract.
4.  The bidder is **unable to meet the required minimum DBE goal** and is **committed to** \_\_\_\_% DBE utilization on this contract and **submits documentation demonstrating good faith efforts.**
5.  The bidder is **unable to meet the required minimum DBE goal** and **submits documentation demonstrating good faith efforts consistent with Appendix A of 49 CFR 26. The Bidder should attach as many pages as necessary to provide a full and complete narrative and supporting documentation of good faith efforts made (See Form 6-C).**

It is the present intent of the Bidder to utilize the specific DBE firms identified on Form 6 – D: DBE Utilization Plan in the execution of this contract. If for any reason, one or more of the DBE identified are unable or unwilling to participate, the Bidder will make good faith efforts to replace the DBE with a similar DBE.

**Note:** The Business Diversity Office will only credit DBE participation that is performed by a TNUCP certified entity at the time of submission.

**Firm/Company Name:** \_\_\_\_\_

**Printed Name:** \_\_\_\_\_ **Title:** \_\_\_\_\_

**Signature:** \_\_\_\_\_ **Date:** \_\_\_\_\_

**NASHVILLE METROPOLITAN TRANSIT AUTHORITY  
GOOD FAITH EFFORT DOCUMENTATION FORM**

**CONTRACT NAME:** \_\_\_\_\_

**NAME OF CONTRACTOR:** \_\_\_\_\_

\*If Contractor is unable to meet the required DBE goal, the Contractor should include all necessary information to provide a full and complete narrative with proposal detailing reasons for Contractor’s inability to meet DBE goal. Contractor’s must provide the requested information below:

Please use as many sheets as necessary to document your efforts.

| DBE Firm Name & Address | Contact Person & Phone Number | NAICS Code: Services<br>or<br>Materials | Reason Rejected |
|-------------------------|-------------------------------|---|-----------------|
|                         |                               |   |                 |
|                         |                               |   |                 |
|                         |                               |   |                 |
|                         |                               |   |                 |
|                         |                               |   |                 |
|                         |                               |   |                 |
|                         |                               |   |                 |
|                         |                               |   |                 |
|                         |                               |   |                 |
|                         |                               |   |                 |

\_\_\_\_\_  
Contractor’s Authorized Signatory

\_\_\_\_\_  
Date

**NASHVILLE METROPOLITAN TRANSIT AUTHORITY**  
**DBE UTILIZATION PLAN**

CONTRACT NAME: \_\_\_\_\_

NAME OF CONTRACTOR: \_\_\_\_\_

The following Disadvantaged Business Enterprises (DBE)s will be used on this Contract:

Please use as many sheets as necessary

| (A)<br>DBE Firm Name & Address   | (B)<br>Contact Person & Phone Number | (C)<br>NAICS Code: Services or Materials | (D)<br>DBE Contract Value |
|--|--------------------------------------|--|---------------------------|
|  |                                      |  |                           |
|  |                                      |  |                           |
|  |                                      |  |                           |
|  |                                      |  |                           |
|  |                                      |  |                           |
|  |                                      |  |                           |
|  |                                      |  |                           |
|  |                                      |  |                           |
|  |                                      |  |                           |
| <b>Total DBE Contract Value (E)</b>  |                                      |  |                           |
| <b>Total Proposed Contract Value(F)</b>  |                                      |  |                           |
| <b>Total DBE Contract Value (E) divided by Total Proposed Contract Value (F) = DBE %</b> |                                      |  |                           |

\_\_\_\_\_  
Contractor's Authorized Signatory

\_\_\_\_\_  
Date



**FORM 7**

**CERTIFICATE OF AUTHORITY**

I hereby declare and affirm that I am:

**CONTRACTOR IS A CORPORATION**

**CONTRACTOR IS A PARTNERSHIP**

**CONTRACTOR IS AN INDIVIDUAL**

**CONTRACTOR IS A JOINT VENTURE**

I, the undersigned, as certified authority of the organization submitting the foregoing Bid, hereby certify that under and pursuant to the By-Laws and Resolutions of said organization, each officers who has signed Bids on behalf of the corporation, including the foregoing assurance of irrevocability, is fully and completely authorized so to do.

\_\_\_\_\_  
Company

\_\_\_\_\_  
Authorized Signature /Date

\_\_\_\_\_  
Name Printed

\_\_\_\_\_  
Title

Subscribed and sworn to before me the \_\_\_\_\_ day of \_\_\_\_\_, 20\_\_\_\_.

\_\_\_\_\_  
Notary Public

My commission expires: \_\_\_\_\_

**FORM 8**

**CERTIFICATION OF RESTRICTIONS ON LOBBYING**

I \_\_\_\_\_ hereby certify on behalf of \_\_\_\_\_  
(Name of Official) (Name of Contractor)

(1) No Federal appropriated funds have been paid or will be paid, by or on behalf of the undersigned, to any person for influencing or attempting to influence an officer or employee of an agency, a Member of Congress, an officer or employee of Congress, or an employee of a Member of Congress in connection with the awarding of any Federal contract, the making of any Federal grant, the making of any Federal loan, the entering into of any cooperative agreement, and the extension, continuation, renewal, amendment, or modification of any Federal contract, grant, loan, or cooperative agreement.

(2) If any funds other than Federal appropriated funds have been paid or will be paid to any person for making lobbying contacts to an officer or employee of any agency, a Member of Congress, an officer or employee of Congress, or an employee of a Member of Congress in connection with this Federal contract, grant, loan, or cooperative agreement, the undersigned shall complete and submit Standard Form--LLL, "Disclosure Form to Report Lobbying," in accordance with its instructions [as amended by "Government wide Guidance for New Restrictions on Lobbying," 61 Fed. Reg. 1413 (1/19/96). Note: Language in paragraph (2) herein has been modified in accordance with Section 10 of the Lobbying Disclosure Act of 1995 (P.L. 104-65, to be codified at 2 U.S.C. 1601, et seq.)]

(3) The undersigned shall require that the language of this certification be included in the award documents for all sub awards at all tiers (including subcontracts, sub grants, and contracts under grants, loans, and cooperative agreements) and that all sub recipients shall certify and disclose accordingly.

This certification is a material representation of fact upon which reliance was placed when this transaction was made or entered into. Submission of this certification is a prerequisite for making or entering into this transaction imposed by 31, U.S.C. § 1352 (as amended by the Lobbying Disclosure Act of 1995). Any person who fails to file the required certification shall be subject to a civil penalty of not less than \$10,000 and not more than \$100,000 for each such failure.

[Note: Pursuant to 31 U.S.C. § 1352(c)(1)-(2)(A), any person who makes a prohibited expenditure or fails to file or amend a required certification or disclosure form shall be subject to a civil penalty of not less than \$10,000 and not more than \$100,000 for each such expenditure or failure.]

The Contractor, \_\_\_\_\_, certifies or affirms the truthfulness and accuracy of each statement of its certification and disclosure, if any. In addition, the Contractor understands and agrees that the provisions of 31 U.S.C. A 3801, et seq., apply to this certification and disclosure, if any.

\_\_\_\_\_  
Company

\_\_\_\_\_  
Authorized Signature /Date

\_\_\_\_\_  
Name Printed

\_\_\_\_\_  
Title

**FORM 9**

**CERTIFICATION REGARDING DEBARMENT AND SUSPENSION PRIMARY PARTICIPANT**

The prospective contractor certifies, by submission of this Bid, that neither it nor its “principals” as defined at 49 CFR 29.995, or affiliates, as defined at 49 CFR 29.905, are presently debarred, suspended, proposed for debarment, declared ineligible, or voluntarily excluded from participation in this transaction by any governmental department or agency as defined at 49 CFR 29.940 and 29.945.

The contractor must comply with 49 CFR 29, Subpart C and must include the requirement to comply with 49 CFR 29, Subpart C in any lower tier covered transaction it enters into.

By signing and submitting its Bid, the Contractor certifies as follows:

The certification in this clause is a material representation of fact relied upon by MTA. If it is later determined that the Contractor knowingly rendered an erroneous certification, in addition to remedies available to MTA, the Federal Government may pursue available remedies, including but not limited to suspension and/or debarment. The Contractor agrees to comply with the requirements of 49 CFR 29, Subpart C while this offer is valid and throughout the period of any contract that may arise from this offer. The Contractor further agrees to include a provision requiring such compliance in its lower tier covered transactions.

---

Company

---

Authorized Signature /Date

---

Name Printed

---

Title

**FORM 10**

**CERTIFICATION OF LOWER-TIER PARTICIPANTS**

**CERTIFICATION REGARDING DEBARMENT AND SUSPENSION**

The prospective lower tier participant contractor certifies, by submission of this Bid, that neither it nor its “principals” as defined at 49 CFR 29.995, or affiliates, as defined at 49 CFR 29.905, are presently debarred, suspended, proposed for debarment, declared ineligible, or voluntarily excluded from participation in this transaction by any governmental department or agency as defined at 49 CFR 29.940 and 29.945.

By signing and submitting its Bid, the Contractor certifies as follows:

The certification in this clause is a material representation of fact relied upon by Nashville MTA. If it is later determined that the Contractor knowingly rendered an erroneous certification, in addition to remedies available to Nashville MTA, the Federal Government may pursue available remedies, including but not limited to suspension and/or debarment. The Contractor agrees to comply with the requirements of 49 CFR 29, Subpart C while this offer is valid and throughout the period of any contract that may arise from this offer. The Contractor further agrees to include a provision requiring such compliance in its lower tier covered transactions.

\_\_\_\_\_  
Company

\_\_\_\_\_  
Authorized Signature /Date

\_\_\_\_\_  
Name Printed

\_\_\_\_\_  
Title

**FORM 11**

**CONTACT INFORMATION OF SIMILAR CONTRACTS/REFERENCES**

*Bidders are requested to supply references for past projects that are most similar to size and scope of the work required in this project. Please provide project name, owner, and contact information for owner including the name, email, and telephone number of the owner's representative that can attest to the work performed. For specialty work that will be performed by a subcontractor, please include references for the subcontractor's work on a separate form signed by the subcontractor.*

1. \_\_\_\_\_  
\_\_\_\_\_  
\_\_\_\_\_
2. \_\_\_\_\_  
\_\_\_\_\_  
\_\_\_\_\_
3. \_\_\_\_\_  
\_\_\_\_\_  
\_\_\_\_\_

\_\_\_\_\_  
Company Name

\_\_\_\_\_  
Authorized Signature /Date

\_\_\_\_\_  
Name Printed

\_\_\_\_\_  
Title

**FORM 12**

**AFFIDAVITS**

State of \_\_\_\_\_ County of \_\_\_\_\_

*As used herein, "Contractor" will include Bidders and.*

**Compliance with Laws:** After first being duly sworn according to law, the undersigned (Affiant) states that he/she is the \_\_\_\_\_ (Title) of \_\_\_\_\_ (Contractor), and that Contractor is presently in compliance with, and will continue to maintain compliance with, all applicable laws. Thus, Affiant states that Contractor has all applicable licenses, including business licenses, copies of which are attached hereto. Finally, Affiant states that Contractor is current on its payment of all applicable gross receipt taxes and personal property taxes.

**Contingent Fees:** In accordance with the Metropolitan Government's 1992 Procurement Code, and MTA Purchasing Policy and FTA rules it is a breach of ethical standards for a person to be retained, or to retain a person, to solicit or secure a Nashville MTA contract upon an agreement or understanding for a contingent commission, percentage, or brokerage fee, except for retention of bona fide employees or bona fide established commercial selling agencies for the purpose of securing business. After first being duly sworn according to law, the undersigned (Affiant) states that the Contractor has not retained anyone in violation of the foregoing.

**Non-Discrimination:** After first being duly sworn according to law, the undersigned (Affiant) states that by its employment policy, standards, and practices the Contractor does not subscribe to any personnel policy which permits or allows for the promotion, demotion, employment, dismissal, or laying off of any individual due to his/her race, creed, color, national origin, age, or sex, and that the Contractor is not in violation of and will not violate any applicable laws concerning the employment of individuals with disabilities.

It is the policy of the Nashville MTA, FTA and the Metropolitan Government not to discriminate on the basis of age, race, sex, color, national origin, or disability in its hiring and employment practices, or in admission to, access to, or operation of its programs, services, and activities. With regard to all aspects of its contract with the Nashville MTA, Contractor certifies and warrants it will comply with this policy.

\_\_\_\_\_  
Company

\_\_\_\_\_  
Authorized Signature /Date

\_\_\_\_\_  
Name Printed

\_\_\_\_\_  
Title

Sworn to and subscribed before me on this \_\_\_\_ day of \_\_\_\_\_, 20\_\_\_\_.

\_\_\_\_\_  
Notary Public  
My commission expires: \_\_\_\_\_

**FORM 13**

**NOTICE TO CONTRACTOR**

The Contractor hereby agrees that the Nashville MTA Chief Executive Officer and or the Board of Directors have the right to reject any or all Bids and to waive informality in any Bid and the Contractor shall not dispute the correctness of the quantities used in computing the best, responsive Bid.

---

Company

---

Authorized Signature /Date

---

Name Printed

---

Title

**FORM 14**

**BUY AMERICA CERTIFICATE**

**(For Procurement of Steel, Iron, or Manufactured Products) (EXCLUDES ROLLING STOCK)**

*Certificate of Compliance with TITLE 49 USC § 5323(j)(1)*

The applicant hereby certifies that it will comply with the requirements of Title 49 USC § 5323(j)(1) and the applicable regulations in 49 CFR Part 661.5.

\_\_\_\_\_  
Company

\_\_\_\_\_  
Authorized Signature /Date

\_\_\_\_\_  
Name Printed

\_\_\_\_\_  
Title

*Certificate of Non-Compliance with TITLE 49 USC §. 5323(j)(1)*

The Applicant hereby certifies that it cannot comply with the requirements of Title 49

USC § 5323(j)(1) and 49 CFR 661.5, but it may qualify for an exception pursuant to Title 49 USC § 5323(j)(2)(A), 5323(j)(2)(B) or 5323(j)(2)(D), and the regulations in 49 CFR 661.7.

\_\_\_\_\_  
Company

\_\_\_\_\_  
Authorized Signature /Date

\_\_\_\_\_  
Name Printed

\_\_\_\_\_  
Title



**FORM 15**

**INTENTIONALLY OMITTED**

Nashville Metropolitan Transit Authority  
Subcontractor Information

ITB Project # 2024171 –Lot Expansion and Improvements

|             |  |       |         |       |  |
|-------------|--|-------|---------|-------|--|
| Bidder Name |  |       | Address |       |  |
| Contact     |  | Email |         | Phone |  |

Please list all subcontractors performing work on the above contract. Use additional sheets, if necessary.

| SUBCONTRACTOR INFORMATION |                |               |         |                    |                |  |
|---------------------------|----------------|---------------|---------|--------------------|----------------|--|
| Company Name              | Contact Person | Email & Phone | Address | Contracted Service | Contract Value |  |
|                           |                |               |         |                    |                |  |
|                           |                |               |         |                    |                |  |
|                           |                |               |         |                    |                |  |
|                           |                |               |         |                    |                |  |
|                           |                |               |         |                    |                |  |
|                           |                |               |         |                    |                |  |
|                           |                |               |         |                    |                |  |
|                           |                |               |         |                    |                |  |
|                           |                |               |         |                    |                |  |
|                           |                |               |         |                    |                |  |
|                           |                |               |         |                    |                |  |
|                           |                |               |         |                    |                |  |
|                           |                |               |         |                    |                |  |
|                           |                |               |         |                    |                |  |
|                           |                |               |         |                    |                |  |
|                           |                |               |         |                    |                |  |

\_\_\_\_\_

**Prime Contractor Signature**

\_\_\_\_\_

**Date**

*Note: This form must be submitted to the Project Manager and DBE Liaison Officer when a subcontractor is added to the project.*

---

---

**This is a Proposed Contract. Nashville MTA reserves the right to make changes in the Contract. Bidders requesting changes to the Contract MUST submit their requests prior to the close of the bid question period . Requests for changes received after this date WILL NOT be considered.**

---

---

**NASHVILLE METROPOLITAN TRANSIT AUTHORITY**  
**AND**  
**CONTRACTOR**  
**FOR CONSTRUCTION SERVICES**  
**LOT EXPANSION AND IMPROVEMENTS**

This Contract No. Project 2024171 (the “**Contract**”) is entered into as of the dated signed by Nashville MTA, by and between Nashville Metropolitan Transit Authority (“**Nashville MTA**”), having its principal office located at 430 Myatt Drive, Nashville, TN 37115, and \_\_\_\_\_ (“**Contractor**”), a [insert state] [insert type of company], having its principal office located at \_\_\_\_\_.

**ORDER OF PRECEDENCE:** The following documents constitute this Contract, and the order of precedence in resolving any dispute that may arise or conflicting provisions:

1. All properly executed amendments to Contract (most recent with first priority)
2. Contract No. Project 2024171
3. The specifications and drawings prepared by the Design Representative for Project # Project # 2024171
4. Invitation to Bid No. Project 2024171 (the “**ITB and the Addenda**”)
5. Contractor’s clarification response dated \_\_\_\_\_, 0:00 P.M.
6. Contractor’s response dated \_\_\_\_\_, 0:00 P.M.  
(Collectively, the “**Contract**” or the “**Contract Documents**”)

1. **CONSTRUCTION SERVICES**

1.0. Project name:

**LOT EXPANSION AND IMPROVEMENTS**

1.1. Contractor shall provide the services to complete the Project as detailed in this Contract, the ITB and all Exhibits to this Contract which are incorporated herein by reference (the “**Construction Services**”). Contractor’s duties and responsibilities are more specifically set forth in the ITB, and the Addenda. All Construction Services under this Contract shall be performed in accordance with the terms and conditions of this Contract, pursuant to good industry practice, and

in conformance with all permits, codes, and applicable laws. Nashville MTA reserves the right to review and approve the sequence of Construction Services.

1.2. Nashville MTA may purchase additional Construction Services offered by Contractor under this Contract (“**Additional Services**”). The Additional Services shall be agreed upon in writing with a properly executed amendment of this Contract between the parties. Additional Services shall be invoiced at the rates specified in the written amendment as agreed to by both parties. The rights and obligations of the parties in this Contract shall pertain to and apply to “Additional Services”, unless stated otherwise in writing.

1.3. Any proposed change to this Contract of the Construction Services shall be submitted to the authorized representative of Nashville MTA for prior approval and shall not become effective unless it is in writing and signed by Contractor and the Chief Executive Officer (CEO) of Nashville MTA or the CEO’s designee. Nashville MTA reserves the right and may order changes or alteration in the Construction Services performed by Contractor. If the changes or alterations affect the Project Price of the Construction Services, the parties must agree as provided in this Contract to the appropriate adjustments, including, but not limited, to the time for completion and compensation for the Construction Services. Contractor may also submit changes to the requirements under the Contract for the benefit of Nashville MTA. Nashville MTA may deny any such proposed change by Contractor or may accept in whole or in part any change by issuing a Change Order that identifies the change, the reasons for the change and the increase or decrease the Project Price, if any.

## **2. TERM**

2.0. Contractor shall commence the performance of this Contract (“**Commencement of Work Date**”) within thirty (60) calendar days after Nashville MTA issues a Notice to Proceed to Contractor. The Construction Services shall begin on the Commencement of Work Date and shall conclude on the date of Final Payment, unless terminated earlier pursuant to the terms of this Contract, but in no event shall Contractor take longer than **Sixty (60) calendar days** to complete the Project to Final Completion after the Commencement of Work Date, not including any Warranty Period as provided in this Contract (“**Term**”).

2.1. Once timely commenced, Contractor shall diligently continue its performance to and until Final Payment of the Project Price, as defined in **Section 4** of this Contract. All limitations of time set forth in this Contract are material and are of the essence of the Contract. This Contract may be extended by the parties with a properly executed written amendment to this Contract.

## **3. PROJECT SCHEDULE**

3.0. Contractor is required to submit original copies of the signed Contract along with required documentation, including, but not limited to, insurance, bonds, signed contracts, safety plan, and Quality Assurance/Quality Control plan, (the “**Required Documents**”) within ten (10)

calendar days prior to the execution of this Contract, unless a later date is otherwise directed by Nashville MTA in writing. Nashville MTA shall give Contractor a written notice to proceed (“**Notice to Proceed**”) to commence the Project after receipt of all Required Documents. Further, the parties agree that the Project Schedule in **Exhibit C** shall not commence until the Notice to Proceed is issued by Nashville MTA. A pre-construction meeting attended by Contractor and Nashville MTA shall be held within five (5) business days of Nashville MTA’s receipt of the Required Documents. Nashville MTA expects to issue the Notice to Proceed at such pre-construction meeting.

3.1. Contractor, promptly after signing the Contract, shall prepare and submit a baseline logic driven man-loaded Project Schedule, attached as **Exhibit C**, that is consistent with Contractor’s obligations under the Contract (“**Project Schedule**”). The Project Schedule shall not exceed time limits currently under the Contract and shall provide for expeditious and practicable execution of the Project.

3.2. Contractor shall keep adequately staffed and properly trained labor and supervisors on the job site in order to complete the Construction Services in accordance with the Project Schedule in **Exhibit C**. Contractor has a continuing duty to perform the Construction Services according to the Contract and consistent with the Project Schedule requirements, provided, however, that completion of Construction Services shall in all cases be subject to extensions for a period of time equal to the delay in completion caused as a result of an Excusable Delay. As used herein, the term “**Excusable Delay**” shall mean any delay in performance due to strikes, lockouts, or other labor or industrial disturbance, civil disturbance, future order of any government, court or regulatory body claiming jurisdiction, act of the public enemy, war, riot, sabotage, blockade, embargo, lightning, earthquake, fire, hurricane, tornado, flood, washout, explosion, unusually inclement weather, moratorium or other unusual delay in obtaining necessary governmental permits or approvals (with Contractor using commercially reasonable efforts to obtain the same) or any other cause whatsoever beyond the reasonable control of Contractor (excluding financial inability to perform) to the extent that in each case of Excusable Delay, Contractor has notified Nashville MTA in writing within five (5) days after the occurrence of each Excusable Delay event and has specified in detail the circumstances constituting the Excusable Delay and the anticipated number of days by which performance is delayed as a result thereof. Nashville MTA, in its sole and reasonable discretion, shall determine whether the delay is an Excusable Delay.

3.3. Contractor agrees to accelerate its performance if it is behind the Project Schedule at no cost to Nashville MTA. Such acceleration of performance includes, but is not limited to, retaining additional manpower, equipment, or other support at Contractor’s sole cost. Upon written notification from Nashville MTA that Contractor fails to attain the timeline as provided in the Project Schedule, Contractor shall immediately create, produce, and implement a written plan (the “**Recovery Schedule**”) for attaining compliance with the terms of the Project Schedule.

3.4. An update of the Project Schedule, or if applicable, the Recovery Schedule with as-built dates evidencing progress shall be submitted by Contractor to Nashville MTA with each Payment Request.

3.5. Contractor shall perform the Construction Services in general accordance with the Project Schedule, or if applicable, the Recovery Schedule, submitted to Nashville MTA.

3.6. Contractor shall also prepare and keep current, for the Design Representative's approval, a schedule of submittals which is coordinated with Contractor's Project Schedule and allows the Design Representative reasonable time to review submittals.

#### **4. COMPENSATION**

4.0. The compensation under this Contract shall not exceed [insert monetary amount] (\$ \_\_\_\_\_) (the "Project Price"). A Notice to Proceed shall be issued for the Project Price. Nashville MTA reserves the right, with an executed written Change Order to exercise any options or alternates provided in **Exhibit D**. Notwithstanding any other provision of this Contract, Contractor is not guaranteed to earn any minimum amount of compensation. Rather, the total amount of compensation Contractor may earn under this Contract shall be based on the authorized and approved Construction Services performed. The obligations of Nashville MTA under this Contract shall automatically terminate upon Final Payment of the Project Price.

4.1. Prior to the Notice to Proceed, Contractor shall prepare and present to Nashville MTA **Contractor's Schedule of Values**, as provided in **Exhibit D**, apportioning the Project Price among the different elements of the Project for purposes of periodic and Final Payment. Contractor's Schedule of Values shall be presented in a format acceptable to Nashville MTA, with such detail and supporting information as Nashville MTA may request. Contractor shall neither imbalance nor artificially inflate any element of the Schedule of Values. Nashville MTA reserves the right, with an executed Change Order, to exercise any options or alternates provided in **Exhibit D**. Contractor shall not use any index for price fluctuations or guides to any formula for adjusting price fluctuations unless specifically agreed upon and set forth in **Exhibit D**. Contractor's Schedule of Values shall be utilized for Contractor's requests for payment ("Payment Requests") but shall only be so utilized after such Schedule of Values has been approved in writing by Nashville MTA.

4.1.1. In its schedule of values, the Contractor is to include no more than ten percent (10%) of its total bid amount for mobilization. The Contractor may submit a request for payment for mobilization upon Nashville MTA's receipt and approval of the Contractor's performance and payment bonds, insurance certificates, schedule of values, project schedule, quality assurance and site safety plans, and proof of having obtained all applicable permits needed to perform the work.

4.1.2. Contractor shall submit Payment Requests to:

[Mta.accountspayable@nashville.gov](mailto:Mta.accountspayable@nashville.gov)

With a copy to: [patrick.hester@nashville.gov](mailto:patrick.hester@nashville.gov)

4.2. Each Payment Request shall be made on or before the 10<sup>th</sup> day of each month for and shall be signed by Contractor and shall constitute Contractor's representation that: (i) the quantity and quality of Construction Services has reached the level for which payment is requested; (ii) the Construction Services have been properly installed or performed in strict compliance with this Contract; (iii) Contractor has paid all Contractor's Agents from previous Payment Requests; and (iii) Contractor affirmatively represents and warrants that all Construction Services for which Nashville MTA has previously paid is free and clear of any lien, claim or other encumbrance of any person whatsoever. Furthermore, Contractor warrants and represents that, upon payment of the Payment Request submitted, title to all work, materials and equipment included in such payment shall be vested in Nashville MTA. Thereafter, Nashville MTA shall review the Payment Request and may also review the work at the Project construction site or elsewhere to determine whether the quantity and quality of the work, materials and equipment of the Construction Services are as represented by the Payment Request and are as required by this Contract. Nashville MTA shall approve in writing the amount which, in the opinion of Nashville MTA, is properly owing to Contractor. Nashville MTA's approval of Contractor's Payment Requests shall not preclude Nashville MTA from the exercise of any of its rights as set forth below. In the event that Nashville MTA makes written demand upon Contractor for amounts previously paid by Nashville MTA as contemplated in this **Section 4.2.**, Contractor shall promptly comply with such demand.

(A) When payment is received from Nashville MTA, Contractor shall within fifteen (15) calendar days pay all of its agents, employees, subcontractors, materialmen, laborers, suppliers and other third parties in connection with the Project (the "**Contractor's Agents**") the amounts they are due for the work covered by such payment. In the event Nashville MTA becomes informed that Contractor has not paid a Contractor's Agent as provided in this **Section 4.2.(A)**, Nashville MTA shall have the right, but not the duty, to issue further checks and payments to Contractor of amounts otherwise due hereunder naming Contractor and any such Contractor's Agent as joint payees. Such joint check procedure, if employed by Nashville MTA, shall create no rights in favor of any person or entity beyond the right of the named payees to payment of the check and shall not be deemed to commit Nashville MTA to repeat the procedure in the future.

(B) Neither payment to Contractor, utilization of the Project for any purpose by Nashville MTA, nor any other act or omission by Nashville MTA shall be interpreted or construed as an acceptance of any work of Contractor not strictly in compliance with this Contract. Further, approval or acceptance by Nashville MTA of any of Contractor's Construction Services under this Contract shall not constitute, or be deemed, a release of the responsibility and liability of Contractor or Contractor's Agents for the exercise of skill

and diligence necessary to fulfill Contractor's responsibilities under this Contract. Nor shall Nashville MTA's approval or acceptance be deemed to be the assumption of responsibility by Nashville MTA for any defect or error in the Construction Services of Contractor or Contractor's Agents.

- (C) Nashville MTA shall have the right to withhold and refuse to make payment, have a right of setoff and, if necessary, may demand the return of a portion or all of the amount previously paid to Contractor due to:
- (1) The quality of a portion, or all, of Contractor's Construction Services not being completed in accordance with the requirements of this Contract;
  - (2) The quantity of Contractor's Construction Services not being completed as represented in Contractor's Payment Request, or otherwise;
  - (3) Contractor's rate of progress being such that, in Nashville MTA's opinion, Substantial Completion or Final Completion, or both, may be inexcusably delayed;
  - (4) Contractor's failure to use Contract funds, previously paid Contractor by Nashville MTA, to pay Contractor's Project-related obligations including, but not limited to Contractor's Agents;
  - (5) Claims made, pending or known against Nashville MTA or its property in relation to this Contract or the acts or omissions of Contractor or any of Contractor's Agents;
  - (6) Nashville MTA's rights to Liquidated Damages;
  - (7) Loss or expenses of Nashville MTA caused by Contractor; or,
  - (8) Contractor's failure or refusal to perform any of its obligations to the satisfaction of Nashville MTA.
- (D) Nashville MTA shall, subject to the rights set forth in this **Section 4.2.**, make reasonable efforts to make payments to Contractor within thirty (30) days of receipt of a Nashville-MTA approved Payment Request.
- (E) Nashville MTA uses an online reporting system: <https://wegotransit.dbesystem.com/> to report contract payments to prime and subcontractors. Each month, Contractor shall report payments received from Nashville MTA as well as payments made to all subcontractors.
- (F) **"Substantial Completion"** is the stage in the progress of the Project when the Project or designated portion thereof is sufficiently complete in accordance with the Contract so that Nashville MTA can occupy or utilize the Project for its intended use. Contractor



shall accomplish Substantial Completion of the Project within **One hundred fifty (150) calendar days** after the Notice to Proceed is issued. When Contractor considers that the Project, or a portion thereof which Nashville MTA agrees to accept separately, is Substantially Complete, Contractor shall prepare and submit to the Contract Officer and Project Manager a comprehensive list of items to be completed or corrected prior to Final Payment. Failure to include an item on such list does not alter the responsibility of Contractor to complete the entire Project in accordance with the Contract. Upon receipt of Contractor's list, Nashville MTA and Design Representative will make an inspection to determine whether the Project, or designated portion thereof, is Substantially Complete. If Nashville MTA or the Design Representative, through their inspection, finds that the Construction Services are not Substantially Complete pursuant to the terms of this Contract, Nashville MTA shall furnish Contractor in writing a punch list for Contractor to complete to Nashville MTA's written satisfaction and approval. If, when completing the punch list, Contractor is required to repeat all, or any portion, of the items in the punch list, Contractor shall bear the cost of such repeat inspection(s), which cost may be deducted by Nashville MTA from any payment then or thereafter due to Contractor. When the Project or designated portion thereof is Substantially Complete, and upon Nashville MTA's confirmation that Contractor's Construction Services are Substantially Complete, Design Representative and/or Nashville MTA will prepare a **Certificate of Substantial Completion** which shall establish the date of Substantial Completion, and shall fix the time within which Contractor shall finish all items on the list accompanying the Certificate. Nothing herein shall change the time limits set forth in **Section 2** or the Project Schedule in **Exhibit C** unless agreed to in writing by the parties. The Certificate of Substantial Completion shall be submitted to Nashville MTA and Contractor for their written acceptance of responsibilities assigned to them in such Certificate.

- (G) When the Project is fully complete and Contractor is ready for a final inspection, Contractor shall notify Nashville MTA in writing. Thereupon, Nashville MTA and Design Representative shall perform a final inspection of the Project. When Nashville MTA and Design Representative determine that the Project is acceptable under the Contract, Design Representative shall promptly issue a final **Certificate for Final Payment** stating that to the best of Design Representative's knowledge, information and belief, and on the basis of Design Representative's on-site visits and inspections, the Project has been completed in accordance with the terms and conditions of the Contract. If Nashville MTA or the Design Representative, through their inspection, finds that the Construction Services are not complete pursuant to the terms of this Contract, Nashville MTA shall furnish Contractor in writing a punch list for Contractor to complete to Nashville MTA's written satisfaction and approval. If, when completing the punch list, Contractor is required to repeat all, or any portion, of the items in the punch list, Contractor shall bear the cost of such repeat inspection(s), which cost may be deducted by Nashville MTA from the Final Payment. Upon issuance of the Certificate for Final

Payment and a determination by Nashville MTA that the Project is complete in full accordance with this Contract and that Contractor has performed all of its obligations to Nashville MTA under this Contract, Nashville MTA shall furnish a final approval for payment to Contractor certifying to Contractor that the Project is complete (“**Final Completion**”) and Contractor is entitled to the remainder of the unpaid Project Price, less any amount withheld, including, but not limited to, Retainage pursuant to this Contract (“**Final Payment**”) if the conditions in Section 4.2.(H) are satisfied. Acceptance of Final Payment by Contractor or Contractor’s Agents constitutes a waiver of any Claims against Nashville MTA, whether or not in writing.

- (H) If Nashville MTA finds that satisfactory progress was achieved during any period for which a progress payment is to be made, Nashville MTA shall authorize payment to be made in full. However, if satisfactory progress has not been made, Nashville MTA may retain a maximum of 10% of the amount of the payment until satisfactory progress is achieved. When the work is Substantially Complete, Nashville MTA may retain from previously withheld funds and future progress payments an amount Nashville MTA considers adequate for protection of Nashville MTA and shall release to the Contractor all the remaining withheld funds. Also, on completion and acceptance of each add-alternate of the contract, for which the price is stated separately in the contract, payment shall be made for the completed work without retention of a percentage.
- (I) If Nashville MTA reasonably believes that Final Completion will be inexcusably delayed, then Nashville MTA shall be entitled, but not required, to withhold from any amounts otherwise due Contractor an amount then believed by Nashville MTA to be adequate to recover Liquidated Damages applicable to such delays. If and when Contractor overcomes the delay in achieving Final Completion, or any part thereof, for which Nashville MTA has withheld payment, then Nashville MTA shall promptly release to Contractor only those funds withheld, but no longer applicable, as Liquidated Damages.
- (J) Prior to being entitled to receive Final Payment and as a condition precedent thereto, Contractor shall furnish to Nashville MTA and/or Design Representative, in the form and manner required by Nashville MTA, if any:
  - (1) An affidavit that all of Contractor’s obligations to Contractor’s Agents and other third parties in connection with the Project have been paid or otherwise satisfied;
  - (2) An affidavit that payrolls, bills for materials and equipment, and other indebtedness connected with the Project for which Nashville MTA or Nashville MTA’s property might be responsible or encumbered (less amounts withheld by Nashville MTA) have been paid or otherwise satisfied;

- (3) All subcontractor utilization and payment reports:
- (4) Separate release of Claims or waivers from each employee, subcontractor, laborer, materialman, supplier or other person or entity who has or might have a claim against Nashville MTA or the Payment Bond;
- (5) If required by Nashville MTA, other data establishing payment or satisfaction of obligations, such as receipts, releases and waivers of liens, Claims or encumbrances arising out of the Contract;
- (6) Affirmative waiver by the Contractor of any and all Claims, if any, against Nashville MTA under the Contract;
- (7) A certificate evidencing that insurance required by the Contract Documents shall remain in force after Final Payment is currently in effect and will not be canceled or allowed to expire until at least thirty (30) calendar days' prior written notice has been given to the Nashville MTA;
- (8) A written statement that Contractor knows of no substantial reason that the insurance will not be renewed to cover the time periods required under the Contract;
- (9) All product warranties, operating manuals, instruction manuals and other record documents, drawings, including, but not limited to, as-is drawings, and things customarily required of Contractor, or expressly required in this Contract, as part of or prior to Project close-out;
- (10) Approval of the Design Representative as set forth in this Contract. and
- (11) Consent(s) of surety to Final Payment;

4.3. Nashville MTA shall compensate Contractor in accordance with the terms and conditions of this Contract at the compensation agreed upon in writing. Notwithstanding anything contained herein to the contrary, the Project Price maximum firm fixed price amount to be paid to Contractor for all Construction Services performed under this Contract shall not exceed the Project Price, unless Additional Services are authorized by Nashville MTA in writing.

4.4. The term “**Design Representative**” as used in this Contract shall mean the Design Representative and/or design or engineering firm or engineer or construction administration entity hired by Nashville MTA to oversee the Contractor’s responsibilities and duties under the Contract.

4.5. The Contractor may be compensated at a percentage, not to exceed ten percent (10%) for cost of work (mark-up) on Additional Services, subcontractor’s expenses and/or Change Orders with the written prior approval of MTA.

## **5. CONTRACTOR'S STAFFING AND PERSONNEL**

5.0. Contractor represents that it employs skilled labor with the expertise to perform the Construction Services and possesses sufficient quantities of labor, equipment and materials for the timely performance of the Construction Services. Furthermore, Contractor has adequate resources to fully perform and complete the Construction Services. Contractor is familiar with the Project site and its conditions and has visited and inspected the site. Contractor is responsible for supervising the performance of the Construction Services, including that of its subcontractors. Furthermore, Contractor is responsible for coordinating the work of all trades on the Project, including its subcontractors and any MTA contractors. Contractor has control over and sole responsibility for the means and methods of construction used to perform the Construction Services, except where otherwise specified in the Contract.

5.1. Contractor shall assign only competent and qualified personnel and staff to perform the Construction Services as set forth in this Contract and shall at all times be solely responsible for the quality of the Construction Services.

5.2. In the event Contractor desires to change such key personnel from performing the Construction Services under this Contract, Contractor shall submit the qualifications of the proposed substituted personnel to Nashville MTA for prior written approval, which shall not be unreasonably withheld.

5.3. Contractor shall promptly remove any employee or subcontractor who is determined by Nashville MTA, in its sole discretion, in writing to Contractor, to be uncooperative, incompetent, a threat to the timely completion of the Construction Services, a threat to the safety of persons or property, or refuses to perform the Construction Services in accordance with the Contract. Rejection by Nashville MTA and the removal of assigned personnel shall not relieve Contractor of its full responsibilities under the Contract. Contractor shall provide written notification to Nashville MTA of any impact on the Project Schedule impacts as a result of such removal, if any.

5.4. Contractor, and Contractor's Agents, found guilty of unethical or irresponsible business practices shall be suspended and debarred from conducting future business with Nashville MTA.

5.5. Contractors and subcontractors must maintain an up-to-date System for Award Management, DUNS number, applicable Tennessee contractor's license, and any other registration databases that are required.

5.6. Contractor must submit all letters of certification of any DBEs participating on this Project.

5.7. Contractor shall comply with the applicable workers' compensation laws in the State of Tennessee and maintain workers' compensation insurance as set forth in **Section 17**.

Contractor shall also require each Contractor's Agent to provide workers' compensation for all of the Contractor Agent's employees who are performing the Construction Services if such employees are not covered by Contractor, and Contractor's written agreement with each Contractor's Agents shall so specify.

5.8. Contractor shall adhere to Nashville MTA's safety requirements and security, which include, but are not limited to, OSHA/TOSHA applicable requirements, the requirement that all Contractor's Agents wear or use body and health protection equipment, wear identification badges, check in with Nashville MTA's supervisor or authorized representative on duty, and sign in and out in a logbook, when applicable, when arriving and departing Nashville MTA's property.

5.9. Contractor shall comply with the laws regarding the employment of aliens and others, so that all persons performing the Construction Services under this Contract meet the citizenship and alien status requirements contained in governmental laws, including, but not limited to, the *Immigration Reform and Control Act of 1986* as amended. Contractor shall obtain from all of its employees performing the Construction Services all verification and other documentation of employment eligibility status required by the laws as they currently exist and as they may hereafter be amended. Contractor shall retain such documentation for all covered employees for the period prescribed by law.

## **6. DISADVANTAGED BUSINESS ENTERPRISE PROGRAM COMPLIANCE**

6.0. Contractor has submitted and the Agency has approved, a 7.5 percent (7.5%) Disadvantaged Business Enterprise ("DBE") Utilization Plan which is attached as **Exhibit F**. This commitment is a percentage of the original contract amount for the utilization of firms owned and controlled by socially and economically disadvantaged individuals. This goal remains in effect throughout the Term of the Contract. Whenever Additional Services or Change Orders are made that individually, or in the aggregate, increase the total dollar value of the Contract, Contractor shall be required to make a good faith effort to maintain the level of 9 percent (9%) DBE participation.

6.1. Terminating/Replacing DBEs on Contract: The Contractor shall utilize the specific DBEs listed in the Contractor's [bid/solicitation] response to perform the work and supply the materials for which each is listed unless the Contractor obtains prior written consent of the Agency to terminate/replace Subcontractor as provided in 49 CFR Part 26, 26.53(f). Unless such consent is provided, the Contractor shall not be entitled to any payment for work or material unless it is performed or supplied by the listed DBE.

6.2. Contractor shall comply with all terms of DBE program. If Contractor is notified that a DBE firm named on its accepted Utilization Plan is unable or unwilling to perform the work, Contractor shall immediately notify the Agency before replacing the firm. Contractor is expected to make a good faith effort to replace the DBE with another DBE firm and is required to submit an updated DBE Utilization Plan

for approval. Examples of good faith efforts can be found in Appendix A to 49 CFR Part 26 – Guidance Concerning Good Faith Efforts.

6.3. Prompt Payment and Retainage: The Contractor agrees to pay each Subcontractor under this Contract for satisfactory performance of its contract no later than **fifteen (15) days** from the receipt of each payment the Contractor receives from the Agency. Any delay or postponement of payment from the above referenced time frame may occur only for good cause following written approval of the Agency. This clause applies to both DBE and non-DBE Subcontracts.

There is no retainage or other sums allowed to be withheld from progress payments or any other payments and any exceptions to this prompt pay/retainage provision must be requested in writing to the Agency and approved in writing.

6.4. The Contractor, Sub-recipient, or Subcontractor shall not discriminate on the basis of race, color, national origin, or sex in the performance of this contract. The Contractor shall carry out applicable requirements of 49 CFR Part 26 in the award and administration of DOT assisted contracts. Failure by the Contractor to carry out these requirements is a material breach of this Contract, which may result in the termination of this Contract or such other remedy as the Agency deems appropriate, which may include, but is not limited to:

1. Withholding monthly progress payments;
2. Assessing sanctions;
3. Liquidated damages; and/or
4. Disqualifying the contractor from future bidding as non-responsible

6.5. Contractor shall keep such records (copies of subcontracts, paid invoices, documentation of correspondence) as are necessary for the Agency to determine compliance with the DBE program contract obligations. the Agency reserves the right to investigate, monitor, and review actions, statements, and documents submitted by the Contractor, and/or Subcontractor (DBE or non-DBE).

## 7. **CONTRACTOR’S REPRESENTATIONS AND WARRANTIES**

Contractor represents and warrants to Nashville MTA as follows:

7.0. Contractor is a **[INSERT TYPE OF BUSINESS ENTITY]** duly organized, validly existing and in good standing under the laws of the State of Tennessee, and has full corporate power and authority to execute, deliver and perform its obligations under this Contract, the Exhibits attached hereto, and any other agreements and instruments contemplated by this Contract. Contractor is fully qualified and has all requisite corporate power and authority to own its properties, inventory, equipment and assets, and to conduct its business as now conducted. Contractor is qualified to do business in all jurisdictions where it is required to perform Construction Services and has and shall maintain all necessary licenses, permits and authorizations required to carry out Contractor’s business for the Project.

7.1. The execution and delivery of this Contract, the Exhibits attached hereto, and the other agreements and instruments contemplated by this Contract have been duly authorized by all necessary actions of Contractor and by anyone else whose approval or authorization is required. Upon execution and delivery, this Contract, the Exhibits attached hereto, and the other agreements and instruments contemplated by this Contract shall be legal, valid and binding obligations of Contractor, enforceable against Contractor in accordance with their respective terms.

7.2. The execution and delivery of this Contract does not, and the execution and delivery of the Exhibits attached hereto and other agreements and instruments contemplated by this Contract will not, and the consummation of the transactions contemplated hereby and thereby will not: (i) violate any provisions of Contractor's charter, bylaws or other organizational documents; (ii) violate any provision of law or any order, judgment or decree of any court or other governmental or regulatory authority applicable to Contractor; (iii) violate or result in a breach of, an acceleration under, or constitute (with due notice or lapse of time or both) a default under, any contract, lease, loan agreement, mortgage, security agreement, or other agreement or instrument to which Contractor is a party or by which it is bound or to which any of Contractor's properties, inventory, or assets is subject, which would prevent Contractor from performing the Construction Services in the manner and as contemplated by and in accordance with the terms and provisions of this Contract; or (iv) result in the imposition of any liens or restrictions on Contractor's business or any properties and inventory, including goods and services, thereof.

7.3. There is no litigation pending or threatened against or relating to Contractor which could materially or adversely affect the Construction Services under this Contract.

7.4. There is not now and will not be at the delivery of the Construction Services to Nashville MTA any damage, destruction or loss not covered by Contractor's insurance which could materially or adversely affect the Construction Services, it being expressly agreed that the risk of loss of the Construction Services shall remain with Contractor until acceptance of the delivery of such Construction Services upon Final Payment by Nashville MTA.

7.5. Contractor shall have and convey at delivery good and marketable title to all of the goods and services encompassing the Project free and clear of all liens, pledges, security interests and encumbrances.

7.6. Contractor and Contractor's Agents shall at all times be in compliance with all applicable local, state and federal laws and regulations and exercise all necessary precautions for the safety of others and the conditions under which the Construction Services are performed.

7.7. Contractor has received, reviewed and carefully examined all of the documents which make up this Contract and finds them to be generally sufficient to indicate and convey understanding of the terms and conditions for implementation and completion of this Project.

7.8. Contractor is not insolvent nor has it filed or had filed against it any proceeding in bankruptcy or for reorganization under any federal bankruptcy law or similar state law, nor has

any receiver been appointed for all or a substantial part of Contractor's assets or business, nor has it made any assignment for the benefit of creditors, nor has it entered into any other proceeding for debt relief. Contractor's business is viable, sound, and operating normally, and there have been no material adverse changes in its business since the date of Contractor's ITB Proposal.

The foregoing representations and warranties of Contractor in this **Section 7** are made with the knowledge and expectation that Nashville MTA is placing complete reliance on such representations and warranties in entering into this Contract and such representations and warranties shall survive the delivery and acceptance of the Construction Services to and by Nashville MTA.

## **8. TAXES.**

8.0. Nashville MTA shall not be responsible for any taxes that are imposed on Contractor. Furthermore, Contractor understands that it cannot claim exemption from taxes by virtue of any exemption that is provided to Nashville MTA.

## **9. INTELLECTUAL PROPERTY INFRINGEMENT.**

9.0. Contractor shall, at its own expense, be entitled to and shall have the duty to defend any suit which may be brought against the Covered Entities to the extent that it is based on a claim that the Construction Services or other work products furnished infringe a copyright, trademark, service mark, or patent or any other intellectual property right. The Contractor shall further indemnify and hold harmless the Covered Entities to the fullest extent permitted by law, and as set forth in **Section 20**, against any award of damages and costs made against the Covered Entities, or any settlement of Claim authorized in writing by Nashville MTA.

9.1. If the Construction Services or other work products furnished under this Contract are likely to, or do become, the subject of such a Claim of infringement, then without diminishing Contractor's obligation to satisfy the award, Contractor may, at its option and expense:

9.1.1. Procure for Nashville MTA the right to continue using the products or services.

9.1.2. Replace or modify the alleged infringing products or services with other equally suitable products or services that are satisfactory to Nashville MTA, so that they become non-infringing.

9.1.3. Remove the products or discontinue the services and cancel any future charges pertaining thereto.

9.1.4. Provided, however, that Contractor will not exercise the option under 9.1.3 until Contractor and Nashville MTA have agreed and determined that the options under both 9.1.1 and 9.1.2 are impractical.



9.2. Contractor shall have no liability to Nashville MTA, however, if any such infringement or Claim thereof is based upon or arises out of:

9.2.1. The use of the Construction Services or other work products in combination with apparatus or devices not supplied or else approved by Contractor.

9.2.2. The use of the Construction Services or other work products in a manner for which the Construction Services or other work products were neither designated nor contemplated.

9.2.3. The claimed infringement in which Nashville MTA has any direct or indirect interest by license or otherwise, is separate from that granted herein.

9.3 Nothing in this **Section 9** precludes Nashville MTA from exercising any rights or remedies as provided elsewhere in this Contract.

## **10. DEFAULT, TERMINATION AND SUSPENSION**

10.0. Should Contractor fail to fulfill in a timely and proper manner its obligations under this Contract or if it should violate any of the terms of this Contract (“**Default**”), then Nashville MTA shall have the right to terminate this Contract provided Contractor fails to cure such Default within ten (10) calendar days of Nashville MTA’s written notice of Default to Contractor. Such termination shall not relieve Contractor of any liability for damages sustained by virtue of any Default by Contractor.

10.0.1. In the event a termination for Default is held to be wrongful, Contractor’s sole and exclusive remedy shall be the amount Contractor would be owed if the termination had been for Nashville MTA’s convenience as set forth below.

10.0.2. In the event of Default by Contractor, Nashville MTA shall be entitled to all of its damages, reasonable expenses, and costs, including, but not limited to its reasonable attorneys’ fees incurred because of such Default.

10.1. Should funding for this Contract be discontinued, Nashville MTA shall have the right to terminate this Contract effective immediately, without penalty, upon written notice to Contractor.

10.2. Nashville MTA may terminate this Contract, in whole or in part, at any time, without penalty, for its convenience or its best interest upon thirty (30) days’ written notice to Contractor.

10.3. In the event of a termination under **Section 10.1.** or **Section 10.2.**, Contractor shall be entitled to compensation for satisfactory, authorized Construction Services completed and accepted as of the notice of termination, but in no event shall MTA be liable to Contractor for compensation for any service which has not been rendered. Additionally, Contractor shall

immediately stop work upon receipt of notice, secure any work site, aid in the transition of the site and take reasonable steps to minimize costs.

10.4. If Contractor has any property in its possession belonging to Nashville MTA as of the notice of termination, Contractor shall account for such property, and dispose of it in the manner as directed by Nashville MTA.

10.5. Nashville MTA may suspend Contractor's continued performance for its convenience, for up to ten (10) calendar days at any one time, by providing written notice to Contractor. Contractor shall not be entitled to any additional payments as a result of such suspension. The extension of ten (10) calendar days will be added to the Project Schedule or Recovery Schedule, if applicable, if this option is exercised.

10.6. Nashville MTA's remedies under this Contract for any Default are non-exclusive and cumulative. Nashville MTA's election of a remedy shall not in any way operate to preclude Nashville MTA from also pursuing all available remedies against Contractor and its sureties for any Default.

## **11. TITLE WARRANTY**

11.0. Contractor warrants that it has good title to and/or the right to sell the Construction Services and represents that the Construction Services delivered to Nashville MTA are free and clear of all liens, Claims or encumbrances of any kind.

11.1. Contractor, at its own expense, shall have the duty to defend any suit which may be brought against the Covered Entities to the extent that it is based on a Claim that the Construction Services or other work products furnished infringe or violate the Contractor's title warranty in **Section 11.0**, and any trademark, patent, copyright, or other intellectual property right. In the event the use of the Construction Services are restricted or interfered with as a result of such infringement or violation, Contractor and Nashville MTA shall have the same rights and responsibilities as set forth in **Sections 9 and 20**.

11.2. Nothing in this **Section 11** precludes Nashville MTA from exercising any rights or remedies as provided elsewhere in this Contract.

## **12. MAINTENANCE OF RECORDS**

12.0. Contractor shall maintain documentation for all charges against Nashville MTA. The books, records, and documents of Contractor, insofar as they relate to Construction Services performed or money received under this Contract, shall be maintained for a period of seven (7) years following the date of Final Payment by Nashville MTA and will be subject to audit, at any reasonable time and upon reasonable notice by Nashville MTA or its duly appointed representatives. The records shall be maintained in accordance with generally accepted accounting principles.

12.1. Contractor's activities conducted and records maintained pursuant to this Contract shall be subject to monitoring and evaluation by the U.S. Department of Transportation, the Comptroller General of the United States General Accounting Office, the Tennessee State Attorney General's office, and Nashville MTA or their duly appointed representatives.

12.2. Any Nashville MTA property, including but not limited to books, records and equipment that is in Contractor's possession shall be maintained by Contractor in good condition and repair, and shall be returned to Nashville MTA by Contractor upon termination of the Contract. All goods, documents, records, work and other work product and property produced by Contractor during the performance of this Contract are deemed to be Nashville MTA property. Upon completion or termination of this Contract, Contractor shall promptly deliver to Nashville MTA all records, notes, data, memorandum, models, and any other material of any nature that are within Contractor's possession or control and that are Nashville MTA property or relate to Nashville MTA or its business.

12.3. Nashville MTA shall retain existing ownership and all proprietary rights to its information and data. Confidential information and data may need to be disclosed to Contractor for purposes necessary to Contractor providing the Construction Services. Contractor shall treat any such data and information as strictly confidential.

12.4. Records pertaining to appeals under disputes, to litigation or to the settlement of Claims arising under or relating to the performance of the Contract shall be made available for seven (7) years after the Commencement of Work Date or until disposition of the appeals, litigation, or Claims, whichever is later.

12.5. Contractor shall include, or have included, the requirements of this **Section 12** in all subcontracts of any tier.

### **13. MODIFICATION OF CONTRACT**

13.0. Contractor must contact Nashville MTA to request any changes to this Contract. This Contract may be modified only by written amendment or Change Order as set forth in **Sections 1, 13 and 25**.

13.1. In the event an alteration or modification in the character of the Construction Services or deliverables results in a change in this Contract, thereby materially increasing or decreasing the scope of Construction Services, cost of performance, or the Project Schedule, the Construction Services or deliverable will nonetheless be performed as directed by Nashville MTA. However, before any altered or modified Construction Services begin, a Change Order or amendment must be approved and executed by Nashville MTA and Contractor.

13.2. Additions to, modifications, or deletions from the Project provided herein may be made, and the compensation to be paid to Contractor may accordingly be adjusted by mutual written agreement of the parties.

13.3. No Claim for extra work done or materials furnished by Contractor will be allowed by Nashville MTA except as provided herein, nor will Contractor perform any Construction Services or furnish any materials not covered by this Contract unless such Construction Services or materials are first authorized in writing by Nashville MTA. Construction Services or materials furnished by Contractor without such prior written authorization shall be Contractor's sole jeopardy, cost, and expense, and Contractor hereby agrees that without prior written authorization, no Claim for compensation for such Construction Services or materials furnished will be made.

13.4. Contractor shall notify Nashville MTA of any proposed changes within ten (10) calendar days of discovering the circumstances that could constitute a change. Contractor waives the right to request any adjustment to the Contract from a change which is not made known to Nashville MTA in writing within such ten (10) calendar day period.

13.5. Contractor shall immediately comply with and strictly adhere to all written instructions and directions given by Nashville MTA (whether or not Contractor disputes or questions such instructions or directions), except to the extent (a) such instruction or directives would constitute a violation of applicable law or (b) Contractor reasonably believes that compliance with such instructions or directions would cause safety hazards to any person or the environment. If Contractor believes that any Nashville MTA instruction or directive constitutes a change to the Contract, Contractor shall provide written notice as required herein, and if no such notice is given, Contractor waives any Claim that such instruction constituted a change in the Contract. If Contractor disputes any instruction or direction of Nashville MTA, such dispute shall be resolved in accordance with **Section 22**. However, Contractor shall comply with all written instructions and directions received from Nashville MTA and shall continue to perform the Construction Services pending the submission of a Claim and the resolution of any resulting dispute.

#### **14. PARTNERSHIP/JOINT VENTURE**

14.0. Nothing herein shall in any way be construed or intended to create a partnership or joint venture between the parties or to create the relationship of principal and agent between or among any of the parties. It is expressly agreed and understood between the parties that Contractor, and any of Contractor's Agents, are independent contractors to Nashville MTA and as such shall be viewed in law and equity. No vicarious liability shall be imposed upon the Covered Entities by any action of Contractor in the performance of this Contract nor shall the doctrine of respondent superior be applicable to the Covered Entities through this Contract. None of the parties hereto shall hold itself out in a manner contrary to the terms of this **Section 14** nor shall Covered Entities or Contractor become liable for any representation, act or omission of any other party contrary to the terms of this **Section 14**.

14.1. Neither Contractor nor Contractor's Agents are Nashville MTA employees. Contractor shall bear sole responsibility for payment of compensation to Contractor's Agents.

## **15. WAIVER**

15.0. No action or failure to act by Nashville MTA, shall constitute a waiver of any right or duty afforded Nashville MTA under this Contract, nor shall any such action or failure to act constitute an approval of or acquiescence in any breach or Default hereunder, except as may be specifically agreed in writing.

15.1. To the extent a waiver occurs by written agreement, such waiver shall not, in any way, be considered a waiver of a subsequent obligation, or the relinquishment of the right to subsequently demand strict performance or exercise such rights set forth in the Contract which shall continue unchanged and remain in full force and effect.

15.2. No waiver of any provision of this Contract shall affect the right of Nashville MTA thereafter to enforce such provision or to exercise any right or remedy available to it in the event of any other Default.

## **16. EMPLOYMENT AND NONDISCRIMINATION**

16.0. In performance of this Contract, Contractor's Agents are prohibited from discriminating against any individual due to race, creed, color, national origin, disability, age, religion or sex and from violating any applicable laws concerning the employment of individuals with disabilities. It is the policy of Nashville MTA not to discriminate on the basis of age, race, creed, religion, sex, color, national origin or disability in its hiring and employment practices, or in admission to, access to, or operation of its programs, services and activities. With regard to all aspects of this Contract, Contractor certifies and warrants that it will comply with this policy and will include this policy in all subcontracts. All solicitations or advertisements for Contractor's Agents placed by or on behalf of Contractor, shall state that all qualified applicants will receive consideration for employment without regard to age, race, sex, color, national origin, creed, religion, and disability.

16.1. Contractor and Contractor's Agents shall not knowingly employ, permit, dispatch, subcontract, or instruct any person who is an undocumented and/or unlawful worker to perform work in whole or part under the terms of this Contract.

16.2. Violation of these Contract provisions may result in suspension or debarment if not resolved in a timely manner to the satisfaction of Nashville MTA.

## **17. INSURANCE AND SURETY BONDS**

17.0. Contractor shall have and maintain insurance in accordance with the requirements set forth herein and in **Exhibit E**. The required certificates of insurance must be provided by Contractor and approved by Nashville MTA before the Notice to Proceed can be issued and before Contractor can commence performance of the Project. Coverage shall remain in effect through any Warranty Period or other Contractual period for correcting defective work or the applicable statute of repose.

17.1. Contractor shall furnish separate performance and payment bonds to Nashville MTA with this Contract, as applicable to the Project as set forth herein and in **Exhibit F**. Each bond shall set forth a penal sum in an amount not less than the Project Price. Each bond furnished by Contractor shall incorporate by reference the terms of this Contract as fully as though they were set forth verbatim in such bonds. In the event the Project Price is adjusted by the execution of a Change Order, the penal sum of both the performance bond and the payment bond shall be deemed adjusted by like amount without consent of the surety. The performance and payment bonds furnished by Contractor shall be in a form suitable to Nashville MTA and shall be executed by a surety, or sureties, licensed to do business in Tennessee and reasonably acceptable to the Nashville MTA. Bonds shall be accompanied by a power of attorney indicating that the person executing the bond is doing so on behalf of the surety. The power of attorney shall have been conferred upon the attorney-in-fact prior to the date of the bond. The power of attorney shall show the date of appointment of the attorney-in-fact and that the appointment and powers have not been revoked and remain in effect.

17.2. Contractor may, subject to Nashville MTA's written approval, at Contractor's sole cost and expense, substitute securities equivalent to and in lieu of any moneys withheld by Nashville MTA to insure performance under this Contract. Such security shall be deposited with a state or federally chartered bank as escrow agent, who shall pay such moneys as provided herein to Contractor upon Final Payment as certified to such bank in writing by Nashville MTA. Nashville MTA shall be the beneficiary of any security substituted for moneys withheld and shall receive any accrued interest thereon. No such substitution shall be accepted until forms of security and any other documentation related to such substitution are reviewed and found acceptable by Nashville MTA.

## **18. CONTINGENT FEES**

18.0. Contractor hereby represents that Contractor has not been retained or retained any persons to solicit or secure a Nashville MTA contract upon an agreement or understanding for a contingent commission, percentage, or brokerage fee, except for retention of bona fide employees or bona fide established commercial selling agencies for the purpose of securing business. Breach of the provisions of this **Section 18** is, in addition to a breach of this Contract, a breach of ethical standards which may result in civil or criminal sanction and/or debarment or suspension from being a contractor or subcontractor under Nashville MTA contracts.

## **19. ETHICAL STANDARDS**

19.0. It shall be a breach of ethical standards for any person to offer, give or agree to give any employee or former employee, or for any employee or former employee of to solicit, demand, accept or agree to accept from another person, a gratuity or an offer of employment in connection with any decision, approval, disapproval, recommendation, preparation of any part of a program requirement or a purchase request, influencing the content of any specification or procurement standard, rendering of advice, investigation, auditing or in any other advisory capacity in any proceeding or application, request for ruling, determination, claim or controversy or other particular

matter, pertaining to any program requirement of a contract or subcontract or to any solicitation or proposal therefore.

19.1. It shall be a breach of ethical standards for any payment, gratuity or offer of employment to be made by or on behalf of a subcontractor under a contract to the prime contractor or higher tier subcontractor or a person associated therewith, as an inducement for the award of a subcontract or order.

19.2. Breach of the provisions of this **Section 19** is, in addition to a Default of this Contract, a breach of ethical standards which may result in civil or criminal sanction and/or debarment or suspension from being a contractor or subcontractor under Nashville MTA contracts.

## **20. INDEMNITY AND CONTRACTOR RESPONSIBILITY**

20.0. Contractor agrees to defend, indemnify and hold harmless, to the fullest extent permitted by law, Nashville MTA, Davidson Transit Organization, the Metro Government of Nashville and Davidson County, and their officers, agents, employees and volunteers (the “**Covered Entities**”) from:

20.1. Any claims, losses, damages, causes of action, suits and liability of every kind, including all expenses of litigation, court costs, and reasonable attorneys’ fees, including, but not limited to, third party claims, for injury to or death of any person or damage to property (“**Claims**”), arising from the Construction Services performed under this Contract, and/or from the negligent or intentional acts or omissions of Contractor, its officers, employees and/or agents, including its sub or independent contractors (including third parties), in connection with the performance of this Contract, and,

20.2. Any Claims arising from any failure of Contractor or Contractor’s Agents, to observe applicable laws, including, but not limited to, workers’ compensation, labor laws and minimum wage laws. Contractor’s indemnification for these Claims is not limited to any statutory limitations on employer liability.

20.3. The indemnity in this **Section 20** applies regardless of whether said Claims are covered, in whole or in part, by insurance and regardless of the negligence, if any, of the Covered Entities.

20.4. Contractor assumes full responsibility for the Construction Services to be performed hereunder and hereby releases, relinquishes, and discharges the Covered Entities from all Claims of every kind and character, including the cost of defense thereof, for any injury to or death of any person (including third parties) and damage to property that are caused by or alleged to be caused by, arising out of, or in connection with Contractor’s Construction Services, Additional Services and work to be performed hereunder. This release shall apply regardless of whether said Claims are covered, in whole or in part, by insurance and regardless of the negligence, if any, of the Covered Entities.

20.5. In the event of any third-party Claim against the Covered Entities, the Covered Entities shall choose counsel, in the Covered Entities' sole and absolute discretion, to represent the Covered Entities, and Contractor shall promptly reimburse the Covered Entities for all costs actually incurred, including, but not limited to, all expenses of litigation, court costs, and reasonable attorneys' fees. The Covered Entities shall be consulted prior to any settlement and any settlement must be approved by the Covered Entities in writing.

20.6. The Covered Entities shall not, under any circumstances, indemnify, defend, or hold harmless Contractor from any Claim.

## **21. SUBCONTRACTORS**

In addition to the other requirements of Contractor set forth herein regarding subcontractors and Contractor's Agents:

21.0. Contractor and its subcontractors shall be licensed as required in the State of Tennessee to perform the Construction Services required by this Contract. Contractor and subcontractors must maintain current Central Contractor Registration ("CCR"), Data Universal Numbering Systems ("DUNS") number, System for Award Management ("SAM"), or registration in other substantially similar registration databases. Contractor must submit to Nashville MTA all Tennessee government letters or certification of any Disadvantaged Business Enterprises ("DBEs") participating in the Project. Contractor is fully responsible for all of the Construction Services that are performed by any subcontractor.

21.1. Contractor shall not subcontract any of its rights or responsibilities in this Contract without the prior written approval of Nashville MTA. Subcontractors, if approved in writing by Nashville MTA, shall be made subject to the applicable terms of this Contract in their contractual agreements with the Contractor. Notwithstanding the foregoing, subcontractors included in Contractor's proposal dated \_\_\_\_\_ are deemed approved. Non-professional, temporary personnel agencies and vendors of standard materials and supplies are not considered subcontractors for purposes of this **Section 21** only.

21.2. Subcontractors, if approved in writing, shall be made and are subject to the applicable terms of this Contract in their contractual agreements with the Contractor. Contractor shall include in its subcontracts the indemnification provision as set forth in **Section 20** running from each subcontractor directly to the Covered Entities.

21.3. Contractor shall hire reliable and dependable subcontractors. Contractor and its subcontractors found guilty of unethical, irresponsible business practices according to governmental authority will be suspended and debarred from conducting future business with Nashville MTA.

21.4. Contractor shall remain fully responsible for the Construction Services of the subcontractor and for supervising the performance of the Construction Services by the



subcontractor. Nashville MTA is not subject to any liability of any kind with respect to any subcontractor, nor do subcontractors obtain any rights against Nashville MTA under this Contract, and Contractor shall so notify subcontractors in its written agreement with subcontractors.

## **22. REMEDIES AND DISPUTES**

22.0. No remedy conferred by any of the specific provisions of this Contract is intended to be exclusive of any other remedy, and each and every remedy shall be cumulative and shall be in addition to every other remedy given under this Contract, now or in the future existing at law or in equity or by statute or otherwise.

22.1. In no event shall Nashville MTA be liable or responsible for payment of special, incidental, indirect, or consequential damages, including, but not limited to, lost profits arising from the performance of this Contract, whether such damages are based in contract, tort, or any other legal theory. Any default or breach by Nashville MTA is limited to its failure to perform certain contractually mandated obligations, such as non-payment.

22.2. The parties agree that any failure of Contractor to attain Final Payment before the expiration of the Term as set forth in **Section 2.0.** of this Contract will cause damage to Nashville MTA. Since the amount of said damages for delay are difficult to determine, the parties agree that the amount of such damages due Nashville MTA for such delay shall be fixed at **LD Amount (“Liquidated Damages”)** for each day after the Term. Contractor agrees to pay Liquidated Damages in said amount and agrees that said Liquidated Damages do not constitute a penalty. Nashville MTA may deduct the amount of the Liquidated Damages from any money due Contractor under the Contract. Nashville MTA shall have the right to pursue the collection of Liquidated Damages as with any other remedy. The Liquidated Damages provided in this **Section 22.2.** apply only to Claims for delays pursuant to this Contract and do not apply or limit any other damages, rights or remedies Nashville MTA may have for other Claims and Default, including, but not limited to, bodily injury, real property damage, infringement, breach of warranty, or for any other damages that may be suffered by Nashville MTA arising out of this Contract or Contractor or Contractor’s Agents’ failure to perform or Default. Contractor shall not be held liable for any delays caused by Nashville MTA, so long as Contractor gives timely notice to Nashville MTA that it maintains that Nashville MTA caused the delay and Nashville MTA acknowledges in writing that it is the cause of said delay.

22.3. Nashville MTA retains the right to supplement the Construction Services and/or replace Contractor if Contractor is in Default. Nashville MTA’s related cost and expense for such supplementation or replacement shall be credited to reduce the remaining Contract balance owed Contractor, if any, after consideration of Nashville MTA’s additional damages.

22.4. In the event of Default of the Contract by Contractor, in addition to any other remedies set forth herein, Contractor shall be liable to Nashville MTA for damages for the breach or Default thereof, including the costs and reasonable attorneys’ fees for the enforcement thereof. The failure or delay of Nashville MTA to exercise a remedy at any time shall not operate as a

waiver of the right to exercise a remedy for the same or subsequent breach or Default at any time thereafter.

22.5. Any disputes arising in the performance of this Contract, which are not resolved by agreement of the parties (“**Dispute**”), shall be decided in writing by Nashville MTA. This decision shall be final and conclusive unless within ten (10) calendar days from the date of receipt of its copy of the written decision of Nashville MTA, Contractor mails or otherwise furnishes a written appeal to Nashville MTA. In connection with any such appeal, Contractor shall be afforded an opportunity to be heard and to offer evidence in support of its position. The decision of Nashville MTA of the appeal shall be binding upon Contractor and Contractor shall abide by the decision.

22.6. Unless otherwise directed by Nashville MTA, Contractor shall continue performance under this Contract during the pendency of any Dispute.

22.7. Unless this Contract specifically provides otherwise, all Claims, counterclaims, and other matters in question between Nashville MTA and Contractor arising out of or relating to this Contract or its breach will be decided by arbitration if the parties mutually agree, or in a court of competent jurisdiction in Davidson County within the State of Tennessee.

### **23. NOTICES**

23.0. Any notice or other communication to be made pursuant to this Contract shall be made in writing and hand delivered by messenger service or delivered by a nationally recognized overnight courier and shall be effective upon receipt. Such notice or other communication shall be made to the address shown below. Either party shall have the right, by written notice to the other party, to change its address for such notice. Electronic mail may be used to expedite communications but shall not be notice under this Contract unless confirmed in writing that such electronic mail serves as notice by the recipient party.

Notices to:

Procurement Department  
Nashville Metropolitan Transit Authority  
430 Myatt Drive  
Nashville, Tennessee 37115  
Attn: Wade McMillian  
Email: [wade.mcmillian@nashville.gov](mailto:wade.mcmillian@nashville.gov)

Notices to Contractor:

Contractor name  
Contractor Address  
City, State Zip Code  
Attn: Name

Email:

**24. ASSIGNMENT - CONSENT REQUIRED**

24.0. The provisions of this Contract shall inure to the benefit of and shall be binding upon the respective successors and assignees of the parties hereto. Neither this Contract nor any of the rights and obligations of Contractor hereunder shall be assigned or transferred in whole or in part without the prior written consent of Nashville MTA, except that in the case of an assignment of compensation due to Contractor, Contractor may assign such right to compensation upon the written consent of Nashville MTA, which shall not be unreasonably withheld. Any such assignment or transfer shall not release Contractor from its obligations hereunder.

24.1. Any public agency (i.e., city, district, public authority, public agency, municipality, and other political subdivision or any FTA-funded entity) shall have the option of participating in this Contract at the same prices, terms, and conditions. Nashville MTA reserves the right to assign any portion of the goods and services awarded under this Contract. This assignment, should it occur, shall be agreed to in writing by Nashville MTA. Once assigned, each agency will enter into its own contract and be solely responsible to Contractor for obligations for the goods and services assigned. Nashville MTA's right of assignment will remain in force until Final Payment. Nashville MTA shall incur no financial responsibility in connection with contracts issued by another public agency. The public agency shall accept sole responsibility for placing orders or payments to Contractor.

**25. ENTIRE CONTRACT**

25.0. This Contract states the entire contract between the parties. No alteration, modification, release, or waiver of this Contract or any of the provisions hereof shall be effective unless in writing, executed by the parties hereto.

25.1. Notwithstanding the foregoing, Contractor agrees that this Contract is subject to modification by Nashville MTA to the extent necessary to comply with federal, state or local regulations, which may govern this Contract. Nashville MTA shall provide written notice to Contractor of any such modification.

**26. FORCE MAJEURE**

26.0. Subject to the provisions of **Section 3.2.**, no party shall have any liability to the other hereunder by reason of any delay or failure to perform any obligation or covenant if the delay or failure to perform is occasioned by force majeure, meaning any act of God, storm, fire, casualty, unanticipated work stoppage, strike, lockout, labor dispute, civil disturbance, riot, war, national emergency, act of Government, act of public enemy, or other cause of similar nature beyond its control.

26.1. In the event of Force Majeure, the Contract shall not be revoked nor shall Contractor be penalized for such noncompliance so long as Contractor complies with **Section 3.2.** and provided that Contractor shall use its best efforts to remove the cause of delay and resume work as soon as possible.

**27. GOVERNING LAW AND VENUE**

27.0. The validity, construction and effect of this Contract and any and all extensions and/or modifications thereof shall be governed by the laws of the State of Tennessee. Tennessee law shall govern regardless of any language in any attachment or other document that Contractor may provide.

27.1. Any action between the parties arising from this Contract shall be maintained in the state trial courts of Davidson County in the State of Tennessee.

**28. SEVERABILITY**

28.0. If any provision of this Contract is properly determined to be illegal, invalid or unenforceable, the other provisions of this Contract shall remain in full force and effect, and such illegal, invalid or unenforceable provision shall be automatically modified in such a manner so as to make it valid, legal and enforceable but keeping it as close to its original meaning as possible.

**29. EFFECTIVE DATE**

29.0. This Contract shall not be binding upon the parties until it has been signed first by Contractor and then by Nashville MTA. When it has been so signed and filed, this Contract shall be effective as of the date signed by Nashville MTA.

**30. COUNTERPARTS**

30.0. This Contract may be executed in one or more identical counterparts, each of which shall be deemed to be an original for all purposes, and all of which taken together shall constitute a single instrument.

**31. MONITORING**

31.0. Nashville MTA and Design Representative shall at all times have access to the Construction Services wherever they are being performed, prepared or in progress. Contractor shall provide safe access to all facilities to enable Nashville MTA and Design Representative to perform its functions and responsibilities under the Contract, and shall provide access for authorized representatives of Nashville MTA and the funding sources (e.g. Federal Transit Administration, Tennessee Department of Transportation, and Federal Railroad Administration) for the purpose of inspecting the work. Nashville MTA and Design Representative shall have the right to obtain or take photographs.

**32. NASHVILLE MTA PROPERTY AND DATA**

32.0. Any Nashville MTA property, including but not limited to books, records and equipment that is in Contractor's possession shall be maintained by Contractor in good condition and repair, and shall be returned to Nashville MTA by Contractor upon termination of this Contract. All goods, documents, records and other work product and property produced during the performance and as a consequence of this Contract are deemed to be Nashville MTA property.

32.1. Nashville MTA will own and retain rights to all of its data. Some data will need to be disclosed to Contractor for purposes necessary for design and implementation. Contractor will treat Nashville MTA information as strictly confidential.

### **33. CONTRACTING OFFICER**

33.0. Nashville MTA's Contracting Officer is the individual with the delegated authority to administer this Contract on behalf of Nashville MTA. The Contracting Officer is solely responsible, under direction from Nashville MTA, for authorizing services by issuing written orders, and for making any changes to the scope of Construction Services, the Project Schedule or other contractual terms and conditions by written contract modification executed by the CEO of Nashville MTA or the CEO's designee. No oral representations of any nature form the basis of or may amend the Contract. The Contracting Officer shall be considered the authorized representative of Nashville MTA, except for modifications of the Contract as provided in **Section 13**.

33.1. The Contracting Officer may delegate certain specific responsibilities to other staff members of Nashville MTA, and if such delegation occurs, Contractor will be notified in writing of the responsible person and his or her duties.

33.2 This Contracting Officer for this Project will be:

Wade McMillian  
[wade.mcmillian@nashville.gov](mailto:wade.mcmillian@nashville.gov)  
Procurement Administrator  
Nashville MTA  
430 Myatt Drive  
Nashville, TN 37115

33.3 The term “**Project Manager**” as used in this Contract shall mean the person designated to oversee the Construction Services.

33.4 Any and all written communications shall make reference to the Contract number and shall be mailed and emailed to the above address.

**34. CONTRACTOR’S LICENSE**

34.0 Contractor swears, affirms and represents that it has complied with all the provisions of Contractors Licensing Act of 1994 of the State of Tennessee, the same being set out in Tennessee Code Annotated, 62-6-101 et seq., and that it is licensed by the State Board of Licensing Contractors. Said Board is authorized to receive complaints relative to Contractor’s professional conduct. Contractor’s license number is [INSERT LICENSE NO.] and the date of expiration is [INSERT DATE], and that part of the classification applying to this Contract is BC; MU-A, B, C, D; HRA.

**35. PREVAILING WAGE RATE**

35.0 Contractor shall not pay less than the prevailing wage rate for all types and classifications for any work performed under this Contract, such rates being those established for Davidson Counties by the United States Department of Labor under 42 U.S.C. § 276 (a) (Davis-Bacon Act). A source for the prevailing wage rates is located at [SAM.gov](http://SAM.gov). Contractor acknowledges and agrees to use the current prevailing wage rates. The prevailing wage rates must be posted at the Project job site. Failure to pay the prevailing wage rate is a material breach of this Contract.

**36. VETERANS EMPLOYMENT HIRING PREFERENCE**

36.0 Nashville MTA and its subrecipients are recipients of federal financial assistance on this Contract. Contractor shall give a hiring preference, to the extent practicable, to veterans, as such term is defined in 5 U.S.C.A. § 2108, who have the requisite skills and abilities to perform the Construction Services required under this Contract. This **Section 36** shall not be understood, construed or enforced in any manner that would require an employer to give a preference to any

veteran over any equally qualified applicant who is a member of any racial or ethnic minority, female, an individual with a disability, or a former employee.

### **37. PUBLICATION AND MEDIA RESTRICTIONS**

37.0. Contractor shall not publish or reproduce any subject matter regarding the Construction Services in whole or in part, or in any manner or form, without the advance written consent of Nashville MTA, unless Nashville MTA has released or approved the release of that data to the public.

### **38. REVIEW OF CONTRACT DOCUMENTS AND FIELD CONDITIONS BY CONTRACTOR**

38.0. Since the Contract Documents are complementary, before starting each portion of the Project, Contractor shall carefully study and compare the various drawings and other Contract Documents relative to that portion of the Project, as well as the information furnished by Nashville MTA, shall take field measurements of any existing conditions related to that portion of the Project and shall observe any conditions at the site affecting that portion of the Project. These obligations are for the purpose of facilitating construction by Contractor and are not for the purpose of discovering errors, omissions, or inconsistencies in the Contract Documents; however, any errors, inconsistencies or omissions discovered by Contractor shall be reported promptly to the Design Representative and Project Manager as a request for information in such form as the Design Representative or Project Manager may require.

### **39. WARRANTY**

39.0. Contractor shall be responsible for using due diligence to correct errors, deficiencies or unacceptable Construction Services. Contractor shall, at no cost to Nashville MTA, remedy any errors, deficiencies or any service, work or other work products found unacceptable, in Nashville MTA's sole discretion, as soon as possible, but in all cases within ten (10) days of Contractor's receipt of written notice of said errors, deficiencies or unacceptable Construction Services. For the Warranty Period, as defined below, Contractor's obligation shall be to replace, resolve or correct, at Contractor's own expense, any defects in the Construction Services.

39.1. Warranty Period is defined as a period of one (1) year(s) beginning on the date of Final Payment, continuing until Contractor has remedied all problems of which Contractor was notified prior to expiration of the warranty period ("**Warranty Period**"). All manufacturer and subcontractors' warranties along with supporting documentation thereof shall be delivered to Nashville MTA.

39.2. If during the Term and applicable Warranty Period any Construction Services do not operate in all material respects as specified in the Contract, Nashville MTA shall be entitled to terminate this Contract for Default in accordance with the terms and conditions of this Contract

and shall be entitled to remedies set forth in **Section 22** including, but not limited to, a full refund for any such defective Construction Services.

39.3. Contractor warrants to Nashville MTA that materials and equipment furnished under the Contract will be of good quality and new, unless otherwise required or permitted by the Contract, that the Project will be free from defects not inherent in the quality required or permitted, and that the Project will conform to the requirements of the Contract. Work not conforming to these requirements, including substitutions not properly approved and authorized, may be considered defective. If required by Design Representative, Contractor shall furnish satisfactory evidence as to the kind and quality of material and equipment.

39.4. Any rights and responsibilities of the parties in this **Section 39** shall survive any termination of the Contract.

#### **40. DOCUMENTS AND SAMPLES AT THE SITE**

40.0. Contractor shall maintain at the site for Nashville MTA one copy of the Project drawings, specifications, addenda, Change Orders and other modifications, in good order and marked currently to record field changes and selections made during construction, and one set record copy of approved Shop Drawings, Product Data, Samples, all as defined herein, and similar submittals required by the Contract Documents (collectively, the “**Submittals**”). The Submittals shall also be available to the Design Representative and Project Manager and be delivered to Nashville MTA upon Final Completion.

40.1. “**Shop Drawings**” are drawings, diagrams, schedules and other data specially prepared for the Project by Contractor, or Contractor’s Agents to illustrate some portion of the Project.

40.2. “**Product Data**” are illustrations, standard schedules, performance charts, instructions, brochures, diagrams and other information furnished by Contractor to illustrate materials or equipment for some portion of the Project.

40.3. “**Samples**” are physical examples which illustrate materials, equipment or workmanship and establish standards by which the Project will be judged.

40.4. The purpose of the Submittals is to demonstrate the way by which Contractor proposes to conform both to the information given and to the design concept expressed in the Contract Documents.

40.5. Contractor shall review the Submittals for compliance with the Contract Documents. If the Submittals are compliant with the Contract Documents, Contractor shall, with reasonable promptness, and in such sequence as to not delay the Construction Services, the activities of Nashville MTA or of separate contractors, approve and submit the Submittals to the Design Representative. The Submittals which the Contractor has not marked as reviewed for compliance



with the Contract Documents or approved by Contractor may be returned to Contractor by the Design Representative without action.

40.6. By approving and submitting the Submittals to Design Representative, Contractor represents that Contractor has determined and verified materials, field measurements and field construction criteria related thereto, and has checked and coordinated the information contained within such Submittals with the requirements of the Project and of the Contract Documents.

40.7. Contractor shall perform no portion of the Project for which the Contract Documents require submittal and review of the Submittals until the respective Submittals have been approved by Design Representative.

#### **41. PARTIAL OCCUPANCY OR USE**

41.0. Nashville MTA may occupy or use any completed or partially completed portion of the Project at any stage when such portion is designated by separate written agreement with Contractor, provided such occupancy or use is approved by the authorized public authorities having jurisdiction over the Project (“**Partial Occupancy or Use**”) and the authorized representatives of Nashville MTA, including the Design Representative.

#### **42. USE OF SITE**

42.0. Contractor shall confine operations at the site to areas permitted by law, ordinances, permits, and the Contract, and shall not unreasonably encumber the site with materials or equipment.

#### **43. CLEANING UP**

43.0. Contractor shall keep the site premises and surrounding area free from accumulation of waste materials or rubbish caused by operations under the Contract. At Final Completion, Contractor shall remove from and about the Project waste materials, rubbish, the Contractor’s tools, construction equipment, machinery and surplus materials.

43.1. If Contractor fails to clean up as provided in the Contract Documents, Nashville MTA may do so and the cost thereof shall be charged to Contractor, which cost shall be due and payable to Nashville MTA upon demand or may be deducted from the Final Payment.

#### **44. COMPLIANCE WITH FEDERAL LAWS AND REGULATIONS**

44.0. All USDOT-required contractual provisions, as set forth in FTA Circular 4220.1F and the FTA contract clauses in the ITB are incorporated by reference. Unless otherwise modified in this Contract, FTA mandated terms shall control in the event of a conflict with other provisions contained in this Contract. Contractor shall not perform any act, fail to perform any act, or refuse to comply with any Nashville MTA request that if not complied with would cause the parties to be in violation of FTA terms and conditions. Contractor shall comply with all applicable FTA

regulations, policies, procedures and directives, including, without limitation, those listed directly or incorporated by reference in the Master Agreement between Nashville MTA and FTA, as may be amended or promulgated from time to time during the Term of this Contract. Contractor's failure to so comply shall constitute a Default of this Contract.

44.1. Contractor represents and warrants that the Construction Services and documentation related thereto shall not be disclosed to any foreign national firm, or country, nor shall be exported from the United States without first complying with all the requirements of the International Traffic in Arms Regulations and the Export Administration Act, including the requirement for obtaining an export license, if applicable. Contractor shall fully indemnify and hold harmless, to the fullest extent permitted by law, Nashville MTA for any breach of this representation.

IN WITNESS WHEREOF, the parties hereto have caused this Contract to be executed on the date and year first above written.

**Nashville Metropolitan Transit Authority**

**Contractor**

\_\_\_\_\_  
Stephen G. Bland, Chief Executive Officer

\_\_\_\_\_  
Signature

\_\_\_\_\_  
Name

\_\_\_\_\_  
Title

\_\_\_\_\_  
Date

\_\_\_\_\_  
Date

**Exhibit A to Contract**  
**Federal Transit Administration Clauses**

**1. Access to Records and Reports**

- a) Record Retention. The Contractor will retain and will require its subcontractors of all tiers to retain, complete and readily accessible records related in whole or in part to the contract, including, but not limited to, data, documents, reports, statistics, sub-Contracts, leases, subcontracts, arrangements, other third-party Contracts of any type, and supporting materials related to those records.
- b) Retention Period. The Contractor agrees to comply with the record retention requirements in accordance with 2 C.F.R. § 200.333. The Contractor shall maintain all books, records, accounts and reports required under this Contract for a period of at not less than three (3) years after the date of termination or expiration of this Contract, except in the event of litigation or settlement of claims arising from the performance of this Contract, in which case records shall be maintained until the disposition of all such litigation, appeals, claims or exceptions related thereto.
- c) Access to Records. The Contractor agrees to provide sufficient access to FTA and its contractors to inspect and audit records and information related to performance of this contract as reasonably may be required.
- d) Access to the Sites of Performance. The Contractor agrees to permit FTA and its contractor's access to the sites of performance under this contract as reasonably may be required.

**2. Americans with Disabilities Act (ADA)**

The contractor agrees to comply with the requirements of 49 U.S.C. § 5301 (d), which states the Federal policy that the elderly and persons with disabilities have the same right as other persons to use mass transportation service and facilities, and that special efforts shall be made in planning and designing those services and facilities to implement that policy. The contractor also agrees to comply with all applicable requirements of section 504 of the Rehabilitation Act of 1973, as amended, 29 U.S.C. § 794, which prohibits discrimination on the basis of handicaps, with the Americans with Disabilities Act of 1990 (ADA), as amended, 42 U.S.C. §§ 12101 et seq., which requires that accessible facilities and services be made available to persons with disabilities, including any subsequent amendments to that Act, and with the Architectural Barriers act of 1968, as amended, 42 U.S.C. §§ 4151 et seq., which requires that buildings and public accommodations be accessible to persons with disabilities, including any subsequent amendments to that Act. In addition, the contractor agrees to comply with any and all applicable requirements issued by the FTA, DOT, DOJ, U.S. GSA, U.S. EEOC, U.S. FCC, any subsequent amendments thereto and any other nondiscrimination statute(s) that may apply to the Project.

**3. Bond Requirements**

Bid Guarantee. Bidders shall furnish a bid guaranty in the form of a bid bond, or certified treasurer's or cashier's check issued by a responsible bank or trust company, made payable to the Agency. The amount of such guaranty shall be equal to the value or a percentage of the total bid price.

In submitting this bid, it is understood and agreed by bidder that the Agency reserves the right to reject any and all bids, or part of any bid, and it is agreed that the Bid may not be withdrawn for a period of [90] days subsequent to the opening of bids, without the written consent of Agency.

It is also understood and agreed that if the undersigned bidder should withdraw any part or all of their bid within [90] days after the bid opening without the written consent of the Agency, or refuse or be unable to enter into this Contract as provided above, or refuse or be unable to furnish adequate and acceptable Performance and Payment Bonds, or refuse or be unable to furnish adequate and acceptable insurance, as provided above, it shall forfeit its bid guaranty to the extent Agency's damages occasioned by such withdrawal, or refusal, or inability to enter into a Contract, or provide adequate security thereof.

It is further understood and agreed that to the extent the defaulting bidder's bid guaranty shall prove inadequate to fully recompense Agency for the damages occasioned by default, then the undersigned bidder agrees to indemnify Agency and pay over to Agency the difference between the bid guarantee and Agency's total damages so as to make Agency whole.

The undersigned understands that any material alteration of any of the above or any of the material contained herein, other than that requested will render the bid unresponsive.

Performance Guarantee. A Performance Guarantee in the amount of 100% of the Contract value is required by the Agency to ensure faithful performance of the Contract. Either a Performance Bond or an Irrevocable Stand-By Letter of Credit shall be provided by the Contractor and shall remain in full force for the term of the Contract. The successful Bidder shall certify that it will provide the requisite Performance Guarantee to the Agency within ten (10) business days from Contract execution. The Agency requires all Performance Bonds to be provided by a fully qualified surety company acceptable to the Agency and listed as a company currently authorized under 31 C.F.R. part 22 as possessing a Certificate of Authority as described hereunder. Agency may require additional performance bond protection when the contract price is increased. The increase in protection shall generally equal 100 percent of the increase in contract price. The Agency may secure additional protection by directing the Contractor to increase the amount of the existing bond or to obtain an additional bond.

If the Bidder chooses to provide a Letter of Credit as its Performance Guarantee, the Bidder shall furnish with its bid, certification that an Irrevocable Stand-By Letter of Credit will be furnished should the Bidder become the successful Contractor. The Bidder shall also provide a statement from the banking institution certifying that an Irrevocable Stand-By Letter of Credit for the action will be provided if the Contract is awarded to the Bidder. The Irrevocable Stand-By Letter of Credit will only be accepted by the Agency if:

1. A bank in good standing issues it. The Agency will not accept a Letter of Credit from an entity other than a bank.
2. It is in writing and signed by the issuing bank.
3. It conspicuously states that it is an irrevocable, non-transferable, "standby" Letter of Credit.
4. The Agency is identified as the Beneficiary.
5. It is in an amount equal to 100% of the Contract value. This amount must be in U.S. dollars.
6. The effective date of the Letter of Credit is the same as the effective date of the Contract
7. The expiration date of the Letter of Credit coincides with the term of the contract.
8. It indicates that it is being issued in order to support the obligation of the Contractor to perform under the Contract. It must specifically reference the Contract between the Agency and the Contractor the work stipulated herein.

The issuing bank's obligation to pay will arise upon the presentation of the original Letter of Credit and a certificate and draft to the issuing bank's representative at a location and time to be determined by the parties. This documentation will indicate that the Contractor is in default under the Contract.

Payment Bonds. A Labor and Materials Payment Bond equal to the full value of the contract must be furnished by the contractor to Agency as security for payment by the Contractor and subcontractors for labor, materials, and rental of equipment. The bond may be issued by a fully qualified surety company acceptable to (Agency) and listed as a company currently authorized under 31 C.F.R. part 223 as possessing a Certificate of Authority as described thereunder.

#### **4. Buy America Requirements**

The contractor agrees to comply with 49 U.S.C. 5323(j) and 49 C.F.R. part 661 and 2 CFR § 200.322 Domestic preferences for procurements, which provide that Federal funds may not be obligated unless all steel, iron, and manufactured products used in FTA funded projects are produced in the United States, unless a waiver has been granted by FTA or the product is subject to a general waiver. General waivers are listed in 49 C.F.R. § 661.7. Separate requirements for rolling stock are set out at 49 U.S.C. 5323(j)(2)(C), 49 U.S.C. § 5323(u) and 49 C.F.R. § 661.11. Domestic preferences for procurements. The bidder or offeror must submit to the Agency the appropriate Buy America certification. Bids or offers that are not accompanied by a completed Buy America certification will be rejected as nonresponsive.

#### **5. Byrd Anti-Lobbying Amendment**

Contractors who apply or bid for an award of \$100,000 or more shall file the required certification. Each tier certifies to the tier above that it will not and has not used Federal appropriated funds to pay any person or organization for influencing or attempting to influence an officer or employee of any agency, a member of Congress, officer or employee of Congress, or an employee of a member of Congress in connection with obtaining any Federal contract, grant, or any other award covered by 31 U.S.C. § 1352. Each tier shall also disclose any lobbying with non-Federal funds that takes place in connection with obtaining any Federal award. Such disclosures are forwarded from tier to tier up to the Agency.

#### **6. Cargo Preference Requirements**

The contractor agrees:

- a) to use privately owned United States-Flag commercial vessels to ship at least 50 percent of the gross tonnage (computed separately for dry bulk carriers, dry cargo liners, and tankers) involved, whenever shipping any equipment, material, or commodities
- b) pursuant to the underlying contract to the extent such vessels are available at fair and reasonable rates for United States-Flag commercial vessels;
- c) to furnish within 20 working days following the date of loading for shipments originating within the United States or within 30 working days following the date of loading for shipments originating outside the United States, a legible copy of a rated, "on-board" commercial ocean bill-of-lading in English for each shipment of cargo described in the preceding paragraph to the Division of National Cargo, Office of Market Development, Maritime Administration, Washington, DC 20590 and to the FTA Recipient (through the contractor in the case of a subcontractor's bill-of-lading.); and
- d) to include these requirements in all subcontracts issued pursuant to this contract when the subcontract may involve the transport of equipment, material, or commodities by ocean vessel.

## 7. Civil Rights Laws and Regulations

The following Federal Civil Rights laws and regulations apply to all contracts.

1. **Federal Equal Employment Opportunity (EEO) Requirements.** These include, but are not limited to:
  - a. Nondiscrimination in Federal Public Transportation Programs. 49 U.S.C. § 5332, covering projects, programs, and activities financed under 49 U.S.C. Chapter 53, prohibits discrimination on the basis of race, color, religion, national origin, sex (including sexual orientation and gender identity), disability, or age, and prohibits discrimination in employment or business opportunity.
  - b. Prohibition against Employment Discrimination. Title VII of the Civil Rights Act of 1964, as amended, 42 U.S.C. § 2000e, and Executive Order No. 11246, “Equal Employment Opportunity,” September 24, 1965, as amended, prohibit discrimination in employment on the basis of race, color, religion, sex, or national origin.
2. **Nondiscrimination on the Basis of Sex.** Title IX of the Education Amendments of 1972, as amended, 20 U.S.C. § 1681 et seq. and implementing Federal regulations, “Nondiscrimination on the Basis of Sex in Education Programs or Activities Receiving Federal Financial Assistance,” 49 C.F.R. part 25 prohibit discrimination on the basis of sex.
3. **Nondiscrimination on the Basis of Age.** The “Age Discrimination Act of 1975,” as amended, 42 U.S.C. § 6101 et seq., and Department of Health and Human Services implementing regulations, “Nondiscrimination on the Basis of Age in Programs or Activities Receiving Federal Financial Assistance,” 45 C.F.R. part 90, prohibit discrimination by participants in federally assisted programs against individuals on the basis of age. The Age Discrimination in Employment Act (ADEA), 29 U.S.C. § 621 et seq., and Equal Employment Opportunity Commission (EEOC) implementing regulations, “Age Discrimination in Employment Act,” 29 C.F.R. part 1625, also prohibit employment discrimination against individuals aged 40 and over on the basis of age.
4. **Federal Protections for Individuals with Disabilities.** The Americans with Disabilities Act of 1990, as amended (ADA), 42 U.S.C. § 12101 et seq., prohibits discrimination against qualified individuals with disabilities in programs, activities, and services, and imposes specific requirements on public and private entities. Third party contractors must comply with their responsibilities under Titles I, II, III, IV, and V of the ADA in employment, public services, public accommodations, telecommunications, and other provisions, many of which are subject to regulations issued by other Federal agencies.

### Civil Rights and Equal Opportunity

The Agency is an Equal Opportunity Employer. As such, the Agency agrees to comply with all applicable Federal civil rights laws and implementing regulations. Apart from inconsistent requirements imposed by Federal laws or regulations, the Agency agrees to comply with the requirements of 49 U.S.C. § 5323(h) (3) by not using any Federal assistance awarded by FTA to support procurements using exclusionary or discriminatory specifications. Under this Contract, the Contractor shall at all times comply with the following requirements and shall include these requirements in each subcontract entered into as part thereof.

1. **Nondiscrimination.** In accordance with Federal transit law at 49 U.S.C. § 5332, the Contractor agrees that it will not discriminate against any employee or applicant for employment because of race, color, religion, national origin, sex, disability, or age. In addition, the Contractor agrees to comply with applicable Federal implementing regulations and other implementing requirements FTA may issue.

2. **Race, Color, Religion, National Origin, Sex.** In accordance with Title VII of the Civil Rights Act, as amended, 42 U.S.C. § 2000e et seq., and Federal transit laws at 49 U.S.C. § 5332, the Contractor agrees to comply with all applicable equal employment opportunity requirements of U.S. Department of Labor (U.S. DOL) regulations, "Office of Federal Contract Compliance Programs, Equal Employment Opportunity, Department of Labor," 41 C.F.R. chapter 60, and Executive Order No. 11246, "Equal Employment Opportunity in Federal Employment," September 24, 1965, 42 U.S.C. § 2000e note, as amended by any later Executive Order that amends or supersedes it, referenced in 42 U.S.C. § 2000e note. The Contractor agrees to take affirmative action to ensure that applicants are employed, and that employees are treated during employment, without regard to their race, color, religion, national origin, or sex (including sexual orientation and gender identity). Such action shall include, but not be limited to, the following: employment, promotion, demotion or transfer, recruitment or recruitment advertising, layoff or termination; rates of pay or other forms of compensation; and selection for training, including apprenticeship. In addition, the Contractor agrees to comply with any implementing requirements FTA may issue.

3. **Age.** In accordance with the Age Discrimination in Employment Act, 29 U.S.C. §§ 621-634, U.S. Equal Employment Opportunity Commission (U.S. EEOC) regulations, "Age Discrimination in Employment Act," 29 C.F.R. part 1625, the Age Discrimination Act of 1975, as amended, 42 U.S.C. § 6101 et seq., U.S. Health and Human Services regulations, "Nondiscrimination on the Basis of Age in Programs or Activities Receiving Federal Financial Assistance," 45 C.F.R. part 90, and Federal transit law at 49 U.S.C. § 5332, the Contractor agrees to refrain from discrimination against present and prospective employees for reason of age. In addition, the Contractor agrees to comply with any implementing requirements FTA may issue.

4. **Disabilities.** In accordance with section 504 of the Rehabilitation Act of 1973, as amended, 29 U.S.C. § 794, the Americans with Disabilities Act of 1990, as amended, 42 U.S.C. § 12101 et seq., the Architectural Barriers Act of 1968, as amended, 42 U.S.C. § 4151 et seq., and Federal transit law at 49 U.S.C. § 5332, the Contractor agrees that it will not discriminate against individuals on the basis of disability. In addition, the Contractor agrees to comply with any implementing requirements FTA may issue.

5. **Promoting Free Speech and Religious Liberty.** The Contractor shall ensure that Federal funding is expended in full accordance with the U.S. Constitution, Federal Law, and statutory and public policy requirements: including, but not limited to, those protecting free speech, religious liberty, public welfare, the environment, and prohibiting discrimination.

## 8. Clean Air Act and Federal Water Pollution Control Act

The Contractor agrees to comply with all applicable standards, orders, or regulations issued pursuant to the Clean Air Act (42 U.S.C. § 7401-7671q) and the Federal Water Pollution Control Act as amended (33 U.S.C. § 1251-1387). Violations must be reported to FTA and the Regional Office of the Environmental Protection Agency. The following applies for contracts of amounts in excess of \$150,000:

### Clean Air Act

- a. The contractor agrees to comply with all applicable standards, orders or regulations issued pursuant to the Clean Air Act, as amended, 42 U.S.C. § 7401 et seq.
- b. The contractor agrees to report each violation to the Agency and understands and agrees that the Agency will, in turn, report each violation as required to assure notification to the Agency, Federal Emergency Management Agency, and the appropriate Environmental Protection Agency Regional Office.
- c. The contractor agrees to include these requirements in each subcontract exceeding \$150,000 financed in whole or in part with Federal assistance provided by FTA.

### Federal Water Pollution Control Act

1. The contractor agrees to comply with all applicable standards, orders or regulations issued pursuant to the Federal Water Pollution Control Act, as amended, 33 U.S.C. 1251 et seq.
2. The contractor agrees to report each violation to the Agency and understands and agrees that the Agency will, in turn, report each violation as required to assure notification to the Agency, Federal Emergency Management Agency, and the appropriate Environmental Protection Agency Regional Office.
3. The contractor agrees to include these requirements in each subcontract exceeding \$150,000 financed in whole or in part with Federal assistance provided by FTA.”

## **9. Contract Work Hours and Safety Standards Act**

- a) Applicability: This requirement applies to all FTA grant and cooperative agreement programs.
- b) Where applicable (see 40 U.S.C. § 3701), all contracts awarded by the non-Federal entity in excess of \$100,000 that involve the employment of mechanics or laborers must include a provision for compliance with 40 U.S.C. §§ 3702 and 3704, as supplemented by Department of Labor regulations at 29 C.F.R. Part 5. See 2 C.F.R. Part 200, Appendix II.
- c) Under 40 U.S.C. § 3702, each contractor must be required to compute the wages of every mechanic and laborer on the basis of a standard work week of 40 hours. Work in excess of the standard work week is permissible provided that the worker is compensated at a rate of not less than one and a half times the basic rate of pay for all hours worked in excess of 40 hours in the work week.
- d) The requirements of 40 U.S.C. § 3704 are applicable to construction work and provide that no laborer or mechanic must be required to work in surroundings or under working conditions which are unsanitary, hazardous or dangerous. These requirements do not apply to the purchases of supplies or materials or articles ordinarily available on the open market, or contracts for transportation or transmission of intelligence.
- e) The regulation at 29 C.F.R. § 5.5(b) provides the required contract clause concerning compliance with the Contract Work Hours and Safety Standards Act:

### Compliance with the Contract Work Hours and Safety Standards Act.

1. Overtime requirements. No contractor or subcontractor contracting for any part of the contract work which may require or involve the employment of laborers or mechanics shall require or permit any such laborer or mechanic in any workweek in which he or she is employed on such work to work in excess of forty hours in such workweek unless such laborer or mechanic receives compensation at a rate not less than one and one-half times the basic rate of pay for all hours worked in excess of forty hours in such workweek.
2. Violation; liability for unpaid wages; liquidated damages. In the event of any violation of the clause set forth in paragraph (1) of this section the contractor and any subcontractor responsible



therefor shall be liable for the unpaid wages. In addition, such contractor and subcontractor shall be liable to the United States (in the case of work done under contract for the District of Columbia or a territory, to such District or to such territory), for liquidated damages. Such liquidated damages shall be computed with respect to each individual laborer or mechanic, including watchmen and guards, employed in violation of the clause set forth in paragraph (1) of this section, in the sum of \$10 for each calendar day on which such individual was required or permitted to work in excess of the standard workweek of forty hours without payment of the overtime wages required by the clause set forth in paragraph (1) of this section.

3. Withholding for unpaid wages and liquidated damages. The agency shall upon its own action or upon written request of an authorized representative of the Department of Labor withhold or cause to be withheld, from any moneys payable on account of work performed by the contractor or subcontractor under any such contract or any other Federal contract with the same prime contractor, or any other federally-assisted contract subject to the Contract Work Hours and Safety Standards Act, which is held by the same prime contractor, such sums as may be determined to be necessary to satisfy any liabilities of such contractor or subcontractor for unpaid wages and liquidated damages as provided in the clause set forth in paragraph (2) of this section.
4. Subcontracts. The contractor or subcontractor shall insert in any subcontracts the clauses set forth in paragraph (1) through (4) of this section and also a clause requiring the subcontractors to include these clauses in any lower tier subcontracts. The prime contractor shall be responsible for compliance by any subcontractor or lower tier subcontractor with the clauses set forth in paragraphs (1) through (4) of this section.”

## **10. Davis Bacon Act and Copeland Anti-Kickback Act**

- a) In accordance with the statute, contractors must be required to pay wages to laborers and mechanics at a rate not less than the prevailing wages specified in a wage determination made by the Secretary of Labor. In addition, contractors must be required to pay wages not less than once a week.
- b) The Non-Federal entity must place a copy of the current prevailing wage determination issued by the Department of Labor in each solicitation. The decision to award a contract or subcontract must be conditioned upon the acceptance of the wage determination. The non-Federal entity must report all suspected or reported violations to the Federal awarding agency.

### “Compliance with the Copeland Anti-Kickback” Act.

1. Contractor. The contractor shall comply with 18 U.S.C. § 874, 40 U.S.C. § 3145, and the requirements of 29 C.F.R. pt. 3 as may be applicable, which are incorporated by reference into this contract.
2. Subcontracts. The contractor or subcontractor shall insert in any subcontracts the clause above and such other clauses as the FTA may by appropriate instructions require, and also a clause requiring the subcontractors to include these clauses in any lower tier subcontracts. The prime contractor shall be responsible for the compliance by any subcontractor or lower tier subcontractor with all of these contract clauses.
3. Breach. A breach of the contract clauses above may be grounds for termination of the contract, and for debarment as a contractor and subcontractor as provided in 29 C.F.R. § 5.12.

## **11. Debarment and Suspension**

- a. Applicability: This requirement applies to all FTA grant and cooperative agreement programs for a contract in the amount of at least \$25,000

(1) This contract is a covered transaction for purposes of 2 C.F.R. pt. 180 and 2 C.F.R. pt. 3000. As such the contractor is required to verify that none of the contractor, its principals (defined at 2 C.F.R. § 180.995), or its affiliates (defined at 2 C.F.R. § 180.905) are excluded (defined at 2 C.F.R. § 180.940) or disqualified (defined at 2 C.F.R. § 180.935).

(2) C.F.R. pt. 3000, subpart C and must include a requirement to comply with these regulations in any lower tier covered transaction it enters into.

(3) The accompanying certification is a material representation of fact relied upon by the subrecipient. If it is later determined that the contractor did not comply with 2 C.F.R. pt. 180, subpart C and 2 C.F.R. pt. 3000, subpart C, in addition to remedies available to the Agency and subrecipient, the Federal Government may pursue available remedies, including but not limited to suspension and/or debarment.

The bidder or proposer agrees to comply with the requirements of 2 C.F.R. pt. 180, subpart C and 2 C.F.R. pt. 3000, subpart C while this offer is valid and throughout the period of any contract that may arise from this offer. The bidder or proposer further agrees to include a provision requiring such compliance in its lower tier covered transactions.

## **12. Disadvantaged Business Enterprise (DBE)**

The contractor or subcontractor shall not discriminate on the basis of race, color, national origin, or sex in the performance of this contract. The contractor shall carry out applicable requirements of 49 C.F.R. part 26 in the award and administration of DOT-assisted contracts. Failure by the contractor to carry out these requirements is a material breach of this contract, which may result in the termination of this contract or such other remedy as the Agency deems appropriate, which may include, but is not limited to:

- (1) Withholding monthly progress payments;
- (2) Assessing sanctions;
- (3) Liquidated damages; and/or
- (4) Disqualifying the contractor from future bidding as non-responsible. 49 C.F.R. § 26.13(b).

Prime contractors are required to pay subcontractors for satisfactory performance of their contracts no later than 30 days from receipt of each payment the Agency makes to the prime contractor. 49 C.F.R. § 26.29(a).

Finally, for contracts with defined DBE contract goals, each FTA Recipient must include in each prime contract a provision stating that the contractor shall utilize the specific DBEs listed unless the contractor obtains the Agency's written consent; and that, unless the Agency's consent is provided, the contractor shall not be entitled to any payment for work or material unless it is performed or supplied by the listed DBE. 49 C.F.R. § 26.53(f) (1).

It is the policy of the Agency and the United States Department of Transportation ("DOT") that Disadvantaged Business Enterprises ("DBE's"), as defined herein and in the Federal regulations published at 49 C.F.R. part 26, shall have an equal opportunity to participate in DOT-assisted contracts.

### **13. DHS Seal, Logo, and Flags**

The contractor shall not use the DHS seal(s), logos, crests, or reproductions of flags or likenesses of DHS agency officials without specific FTA pre-approval.

### **14. Energy Conservation**

The contractor agrees to comply with mandatory standards and policies relating to energy efficiency, which are contained in the state energy conservation plan issued in compliance with the Energy Policy and Conservation Act.

### **15. Equal Employment Opportunity**

During the performance of this contract, the contractor agrees as follows:

(1) The contractor will not discriminate against any employee or applicant for employment because of race, color, religion, sex, sexual orientation, gender identity, or national origin. The contractor will take affirmative action to ensure that applicants are employed, and that employees are treated during employment, without regard to their race, color, religion, sex, sexual orientation, gender identity, or national origin. Such action shall include, but not be limited to the following: Employment, upgrading, demotion, or transfer, recruitment or recruitment advertising; layoff or termination; rates of pay or other forms of compensation; and selection for training, including apprenticeship. The contractor agrees to post in conspicuous places, available to employees and applicants for employment, notices to be provided by the contracting officer setting forth the provisions of this nondiscrimination clause.

(2) The contractor will, in all solicitations or advertisements for employees placed by or on behalf of the contractor, state that all qualified applicants will receive consideration for employment without regard to race, color, religion, sex, sexual orientation, gender identity, or national origin.

(3) The contractor will not discharge or in any other manner discriminate against any employee or applicant for employment because such employee or applicant has inquired about, discussed, or disclosed the compensation of the employee or applicant or another employee or applicant. This provision shall not apply to instances in which an employee who has access to the compensation information of other employees or applicants as a part of such employee's essential job functions discloses the compensation of such other employees or applicants to individuals who do not otherwise have access to such information, unless such disclosure is in response to a formal complaint or charge, in furtherance of an investigation, proceeding, hearing, or action, including an investigation conducted by the employer, or is consistent with the contractor's legal duty to furnish information.

(4) The contractor will send to each labor union or representative of workers with which it has a collective bargaining agreement or other contract or understanding, a notice to be provided by the agency contracting officer, advising the labor union or workers' representative of the contractor's commitments under section 202 of Executive Order 11246 of September 24, 1965, and shall post copies of the notice in conspicuous places available to employees and applicants for employment.

(5) The contractor will comply with all provisions of Executive Order 11246 of September 24, 1965, and of the rules, regulations, and relevant orders of the Secretary of Labor.

(6) The contractor will furnish all information and reports required by Executive Order 11246 of September 24, 1965, and by the rules, regulations, and orders of the Secretary of Labor, or pursuant thereto, and will permit access to his books, records, and accounts by the contracting agency and the Secretary of Labor for purposes of investigation to ascertain compliance with such rules, regulations, and orders.

(7) In the event of the contractor's non-compliance with the nondiscrimination clauses of this contract or with any of such rules, regulations, or orders, this contract may be canceled, terminated or suspended in whole or in part and the contractor may be declared ineligible for further Government contracts in accordance with procedures authorized in Executive Order 11246 of September 24, 1965, and such other sanctions may be imposed and remedies invoked as provided in Executive Order 11246 of September 24, 1965, or by rule, regulation, or order of the Secretary of Labor, or as otherwise provided by law.

(8) The contractor will include the provisions of paragraphs (1) through (8) in every subcontract or purchase order unless exempted by rules, regulations, or orders of the Secretary of Labor issued pursuant to section 204 of Executive Order 11246 of September 24, 1965, so that such provisions will be binding upon each subcontractor or vendor. The contractor will take such action with respect to any subcontract or purchase order as may be directed by the Secretary of Labor as a means of enforcing such provisions including sanctions for noncompliance: Provided, however, that in the event the contractor becomes involved in, or is threatened with, litigation with a subcontractor or vendor as a result of such direction, the contractor may request the United States to enter into such litigation to protect the interests of the United States.

## 16. Federal Changes

49 CFR Part 18 Federal Changes - Contractor shall at all times comply with all applicable FTA regulations, policies, procedures and directives, including without limitation those listed directly or by reference in the Master Agreement between Purchaser and FTA, as they may be amended or promulgated from time to time during the term of this contract. Contractor's failure to so comply shall constitute a material breach of this contract.

## 17. Fly America

6. Definitions. As used in this clause—

- 1) “International air transportation” means transportation by air between a place in the United States and a place outside the United States or between two places both of which are outside the United States.
- 2) “United States” means the 50 States, the District of Columbia, and outlying areas.
- 3) “U.S.-flag air carrier” means an air carrier holding a certificate under 49 U.S.C. Chapter 411.

7. When Federal funds are used to fund travel, Section 5 of the International Air Transportation Fair Competitive Practices Act of 1974 (49 U.S.C. 40118) (Fly America Act) requires contractors, Agency’s, and others use U.S.-flag air carriers for U.S. Government-financed international air transportation of personnel (and their personal effects) or property, to the extent that service by those carriers is available. It requires the Comptroller General of the United States, in the absence of satisfactory proof of the necessity for foreign-flag air transportation, to disallow expenditures from funds, appropriated or otherwise established for the account of the United States, for

international air transportation secured aboard a foreign-flag air carrier if a U.S.-flag air carrier is available to provide such services.

8. If available, the Contractor, in performing work under this contract, shall use U.S.-flag carriers for international air transportation of personnel (and their personal effects) or property.
9. In the event that the Contractor selects a carrier other than a U.S.-flag air carrier for international air transportation, the Contractor shall include a statement on vouchers involving such transportation essentially as follows:

Statement of Unavailability of U.S. – Flag Air Carriers

International air transportation of persons (and their personal effects) or property by U.S.-flag air carrier was not available or it was necessary to use foreign-flag air carrier service for the following reasons. See FAR § 47.403. [State reasons]:

10. Contractor shall include the substance of this clause, including this paragraph (e), in each subcontract or purchase under this contract that may involve international air transportation.

## **18. Incorporation of Federal Transit Administration (FTA) Terms**

Incorporation of Federal Transit Administration (FTA) Terms - The provisions within include, in part, certain Standard Terms and Conditions required by DOT, whether or not expressly set forth in the preceding contract provisions. All contractual provisions required by DOT, as set forth in the current FTA Circular 4220 are hereby incorporated by reference. Anything to the contrary herein notwithstanding, all FTA mandated terms shall be deemed to control in the event of a conflict with other provisions contained in this Contract. The Contractor shall not perform any act, fail to perform any act, or refuse to comply with any request which would cause a violation of the FTA terms and conditions.

## **19. No Government Obligation to Third Parties**

The Agency and Contractor acknowledge and agree that, notwithstanding any concurrence by the Federal Government in or approval of the solicitation or award of the underlying Contract, absent the express written consent by the Federal Government, the Federal Government is not a party to this Contract and shall not be subject to any obligations or liabilities to the Agency, Contractor or any other party (whether or not a party to that contract) pertaining to any matter resulting from the underlying Contract. The Contractor agrees to include the above clause in each subcontract financed in whole or in part with Federal assistance provided by the FTA. It is further agreed that the clause shall not be modified, except to identify the subcontractor who will be subject to its provisions.

## **20. Notification to FTA**

If a current or prospective legal matter that may affect the Federal Government emerges, the Recipient must promptly notify the FTA Chief Counsel and FTA Regional Counsel for the Region in which the Recipient is located. The Recipient must include a similar notification requirement in its Third-Party Agreements and must require each Third Party Participant to include an equivalent provision in its sub agreements at every tier, for any agreement that is a “covered transaction” according to 2 C.F.R. §§ 180.220 and 1200.220.

- (1) The types of legal matters that require notification include, but are not limited to, a major dispute, breach, default, litigation, or naming the Federal Government as a party to litigation or a legal disagreement in any forum for any reason.
- (2) Matters that may affect the Federal Government include, but are not limited to, the Federal Government’s interests in the Award, the accompanying Underlying Agreement, and any

Amendments thereto, or the Federal Government’s administration or enforcement of federal laws, regulations, and requirements.

- (3) The Recipient must promptly notify the U.S. DOT Inspector General in addition to the FTA Chief Counsel or Regional Counsel for the Region in which the Recipient is located, if the Recipient has knowledge of potential fraud, waste, or abuse occurring on a Project receiving assistance from FTA. The notification provision applies if a person has or may have submitted a false claim under the False Claims Act, 31 U.S.C. § 3729 et seq., or has or may have committed a criminal or civil violation of law pertaining to such matters as fraud, conflict of interest, bribery, gratuity, or similar misconduct. This responsibility occurs whether the Project is subject to this Agreement or another agreement between the Recipient and FTA, or an agreement involving a principal, officer, employee, agent, or Third-Party Participant of the Recipient. It also applies to subcontractors at any tier. Knowledge, as used in this paragraph, includes, but is not limited to, knowledge of a criminal or civil investigation by a Federal, state, or local law enforcement or other investigative agency, a criminal indictment or civil complaint, or probable cause that could support a criminal indictment, or any other credible information in the possession of the Recipient.

## **21. Procurement of Recovered Materials**

- (1) In the performance of this contract, the Contractor shall make maximum use of products containing recovered materials that are EPA- designated items unless the product cannot be acquired—
  - i. Competitively within a timeframe providing for compliance with the contract performance schedule;
  - ii. Meeting contract performance requirements; or
  - iii. At a reasonable price.
- (2) Information about this requirement, along with the list of EPA-designate items, is available at EPA’s Comprehensive Procurement Guidelines web site, <https://www.epa.gov/smm/comprehensive-procurement-guideline-cpg-program>.”

## **22. Program Fraud and False or Fraudulent Statements and Related Acts**

The contractor acknowledges that 31 U.S.C. Chap. 38 (Administrative Remedies for False Claims and Statements) applies to the contractor’s actions pertaining to this contract.

## **23. Prompt Payment**

The contractor is required to pay its subcontractors performing work related to this contract for satisfactory performance of that work no later than 15 days after the contractor’s receipt of payment for that work. In addition, the contractor is required to return any retainage payments to those subcontractors within 30 days after the subcontractor’s work related to this contract is satisfactorily completed.

The contractor must promptly notify the Agency, whenever a DBE subcontractor performing work related to this contract is terminated or fails to complete its work and must make good faith efforts to engage another DBE subcontractor to perform at least the same amount of work. The contractor may not terminate any DBE subcontractor and perform that work through its own forces or those of an affiliate without prior written consent of the Agency.

## **24. Safe Operation of Motor Vehicles**

### **Seat Belt Use**

The Contractor is encouraged to adopt and promote on-the-job seat belt use policies and programs for its employees and other personnel that operate company-owned vehicles, company rented vehicles, or personally operated vehicles. The terms “company-owned” and “company-leased” refer to vehicles owned or leased either by the Contractor or Agency.

### **Distracted Driving**

The Contractor agrees to adopt and enforce workplace safety policies to decrease crashes caused by distracted drivers, including policies to ban text messaging while using an electronic device supplied by an employer, and driving a vehicle the driver owns or rents, a vehicle Contractor owns, leases, or rents, or a privately-owned vehicle when on official business in connection with the work performed under this Contract.

## **25. Seismic Safety**

The contractor agrees that any new building or addition to an existing building will be designed and constructed in accordance with the standards for Seismic Safety required in Department of Transportation (DOT) Seismic Safety Regulations 49 C.F.R. part 41 and will certify to compliance to the extent required by the regulation. The contractor also agrees to ensure that all work performed under this contract, including work performed by a subcontractor, is in compliance with the standards required by the Seismic Safety regulations and the certification of compliance issued on the project.

## **26. Simplified Acquisition Threshold**

Contracts for more than the simplified acquisition threshold, which is the inflation adjusted amount determined by the Civilian Agency Acquisition Council and the Defense Acquisition Regulations Council (Councils) as authorized by 41 U.S.C. § 1908, or otherwise set by law, must address administrative, contractual, or legal remedies in instances where contractors violate or breach contract terms, and provide for such sanctions and penalties as appropriate. (Note that the simplified acquisition threshold determines the procurement procedures that must be employed pursuant to 2 C.F.R. §§ 200.317–200.327. The simplified acquisition threshold does not exempt a procurement from other eligibility or processes requirements that may apply. For example, Buy America’s eligibility and process requirements apply to any procurement in excess of \$150,000. 49 U.S.C. § 5323(j)(13).)

## **27. Special DOL EEO Clause**

Applies to construction contracts > \$10,000; This contractor and subcontractor shall abide by the requirements of 41 CFR 60-1.4(a), 60-300.5(a) and 60- 741.5(a). These regulations prohibit discrimination against qualified individuals based on their status as protected veterans or individuals with disabilities and prohibit discrimination against all individuals based on their race, color, religion, sex, sexual orientation, gender identity or national origin. Moreover, these regulations require that covered prime contractors and subcontractors take affirmative action to employ and advance in employment individuals without regard to race, color, religion, sex, sexual orientation, gender identity, national origin, disability or veteran status.

## **28. Termination**

### Termination for Convenience (General Provision)

The Agency may terminate this contract, in whole or in part, at any time by written notice to the Contractor when it is in the Agency's best interest. The Contractor shall be paid its costs, including contract close-out costs, and profit on work performed up to the time of termination. The Contractor shall promptly submit its termination claim to Agency to be paid the Contractor. If the Contractor has any property in its possession belonging to Agency, the Contractor will account for the same, and dispose of it in the manner Agency directs.

### Termination for Default [Breach or Cause] (General Provision)

If the Contractor does not deliver supplies in accordance with the contract delivery schedule, or if the contract is for services, the Contractor fails to perform in the manner called for in the contract, or if the Contractor fails to comply with any other provisions of the contract, the Agency may terminate this contract for default. Termination shall be effected by serving a Notice of Termination on the Contractor setting forth the manner in which the Contractor is in default. The Contractor will be paid only the contract price for supplies delivered and accepted, or services performed in accordance with the manner of performance set forth in the contract. If it is later determined by the Agency that the Contractor had an excusable reason for not performing, such as a strike, fire, or flood, events which are not the fault of or are beyond the control of the Contractor, the Agency, after setting up a new delivery of performance schedule, may allow the Contractor to continue work, or treat the termination as a Termination for Convenience.

### Opportunity to Cure (General Provision)

The Agency, in its sole discretion may, in the case of a termination for breach or default, allow the Contractor [an appropriately short period of time] in which to cure the defect. In such case, the Notice of Termination will state the time period in which cure is permitted and other appropriate conditions. If Contractor fails to remedy to Agency's satisfaction the breach or default of any of the terms, covenants, or conditions of this Contract within [10 days] after receipt by Contractor of written notice from Agency setting forth the nature of said breach or default, Agency shall have the right to terminate the contract without any further obligation to Contractor. Any such termination for default shall not in any way operate to preclude Agency from also pursuing all available remedies against Contractor and its sureties for said breach or default.

### Waiver of Remedies for any Breach

In the event that Agency elects to waive its remedies for any breach by Contractor of any covenant, term or condition of this contract, such waiver by Agency shall not limit Agency's remedies for any succeeding breach of that or of any other covenant, term, or condition of this contract.

### Termination for Convenience (Professional Service Contracts)

The Agency, by written notice, may terminate this contract, in whole or in part, when it is in the Agency's interest. If this contract is terminated, the Agency shall be liable only for payment under the payment provisions of this contract for services rendered before the effective date of termination.

## **29. Veterans Hiring Preference**

Veterans Employment - Recipients of Federal financial assistance shall ensure that contractors working on a capital project funded using such assistance give a hiring preference, to the extent practicable, to veterans (as defined in section 2108 of title 5) who have the requisite skills and abilities to perform the



construction work required under the contract. This subsection shall not be understood, construed or enforced in any manner that would require an employer to give a preference to any veteran over any equally qualified applicant who is a member of any racial or ethnic minority, female, an individual with a disability, or a former employee.

### **30. Violation and Breach of Contract**

#### Rights and Remedies of the Agency

The Agency shall have the following rights in the event that the Agency deems the Contractor guilty of a breach of any term under the Contract.

- a. The right to take over and complete the work or any part thereof as agency for and at the expense of the Contractor, either directly or through other contractors;
- b. The right to cancel this Contract as to any or all of the work yet to be performed;
- c. The right to specific performance, an injunction or any other appropriate equitable remedy; and
- d. The right to money damages.

For purposes of this Contract, breach shall include.

#### Rights and Remedies of Contractor

Inasmuch as the Contractor can be adequately compensated by money damages for any breach of this Contract, which may be committed by the Agency, the Contractor expressly agrees that no default, act or omission of the Agency shall constitute a material breach of this Contract, entitling Contractor to cancel or rescind the Contract (unless the Agency directs Contractor to do so) or to suspend or abandon performance.

#### Remedies

Substantial failure of the Contractor to complete the Project in accordance with the terms of this Contract will be a default of this Contract. In the event of a default, the Agency will have all remedies in law and equity, including the right to specific performance, without further assistance, and the rights to termination or suspension as provided herein. The Contractor recognizes that in the event of a breach of this Contract by the Contractor before the Agency takes action contemplated herein, the Agency will provide the Contractor with sixty (60) days written notice that the Agency considers that such a breach has occurred and will provide the Contractor a reasonable period of time to respond and to take necessary corrective action.

#### Disputes

Disputes arising in the performance of this Contract that are not resolved by agreement of the parties shall be decided in writing by an authorized representative of Agency. This decision shall be final and conclusive unless within [10] days from the date of receipt of its copy, the Contractor mails or otherwise furnishes a written appeal to the Agency's authorized representative. In connection with any such appeal, the Contractor shall be afforded an opportunity to be heard and to offer evidence in support of its position. The decision of the Agency's authorized representative shall be binding upon the Contractor and the Contractor shall abide by the decision.

In the event that a resolution of the dispute is not mutually agreed upon, the parties can agree to mediate the dispute or proceed with litigation. Notwithstanding any provision of this section, or any other provision of this Contract, it is expressly agreed and understood that any court proceeding arising out of a dispute under the Contract shall be heard by a Court de novo and the court shall not be limited in such

proceeding to the issue of whether the Authority acted in an arbitrary, capricious or grossly erroneous manner.

Pending final settlement of any dispute, the parties shall proceed diligently with the performance of the Contract, and in accordance with the Agency's direction or decisions made thereof.

#### Performance during Dispute

Unless otherwise directed by Agency, Contractor shall continue performance under this Contract while matters in dispute are being resolved.

#### Claims for Damages

Should either party to the Contract suffer injury or damage to person or property because of any act or omission of the party or of any of its employees, agents or others for whose acts it is legally liable, a claim for damages therefor shall be made in writing to such other party within a reasonable time after the first observance of such injury or damage.

#### Remedies

Unless this Contract provides otherwise, all claims, counterclaims, disputes and other matters in question between the Agency and the Contractor arising out of or relating to this Contract or its breach will be decided by arbitration if the parties mutually agree, or in a court of competent jurisdiction within the State in which the Agency is located.

#### Rights and Remedies

The duties and obligations imposed by the Contract documents and the rights and remedies available thereunder shall be in addition to and not a limitation of any duties, obligations, rights and remedies otherwise imposed or available by law. No action or failure to act by the Agency or Contractor shall constitute a waiver of any right or duty afforded any of them under the Contract, nor shall any such action or failure to act constitute an approval of or acquiescence in any breach thereunder, except as may be specifically agreed in writing.

**Exhibit B to Contract**  
**Tennessee State Contract Clauses**

**Conflicts of Interest.**

The Grantee warrants that no part of the total Grant Contract Amount shall be paid directly or indirectly to an employee or official of the State of Tennessee as wages, compensation, or gifts in exchange for acting as an officer, agent, employee, subcontractor, or consultant to the Grantee in connection with any work contemplated or performed relative to this Grant Contract

**Lobbying.**

The Grantee certifies, to the best of its knowledge and belief, that:

- a. No federally appropriated funds have been paid or will be paid, by or on behalf of the undersigned, to any person for influencing or attempting to influence an officer or employee of an agency, a Member of Congress, an officer or employee of Congress, or an employee of a Member of Congress in connection with the awarding of any federal contract, the making of any federal grant, the making of any federal loan, the entering into of any cooperative agreement, and the extension, continuation, renewal, amendment, or modification of any federal contract, grant, loan, or cooperative agreement.
- b. If any funds other than federally appropriated funds have been paid or will be paid to any person for influencing or attempting to influence an officer or employee of any agency, a Member of Congress, an officer or employee of Congress, or an employee of a Member of Congress in connection with this contract, grant, loan, or cooperative agreement, the Grantee shall complete and submit Standard Form-LLL, "Disclosure of Lobbying Activities," in accordance with its instructions.
- c. The Grantee shall require that the language of this certification be included in the award documents for all sub-awards at all tiers (including subcontracts, sub-grants, and contracts under grants, loans, and cooperative agreements) and that all subrecipients shall certify and disclose accordingly.

This certification is a material representation of fact upon which reliance was placed when this transaction was made or entered into and is a prerequisite for making or entering into this transaction imposed by 31 U.S.C. § 1352

**Nondiscrimination.**

The Grantee hereby agrees, warrants, and assures that no person shall be excluded from participation in, be denied benefits of, or be otherwise subjected to discrimination in the performance of this Grant Contract or in the employment practices of the Grantee on the grounds of handicap or disability, age, race, color, religion, sex, national origin, or any other classification protected by federal, Tennessee state constitutional, or statutory law. The Grantee shall, upon request, show proof of nondiscrimination and shall post in conspicuous places, available to all employees and applicants, notices of nondiscrimination.

### **Public Accountability.**

If the Grantee is subject to Tenn. Code Ann. § 8-4-401 et seq., or if this Grant Contract involves the provision of services to citizens by the Grantee on behalf of the State, the Grantee agrees to establish a system through which recipients of services may present grievances about the operation of the service program. The Grantee shall also display in a prominent place, located near the passageway through which the public enters in order to receive Grant supported services, a sign at least eleven inches (11") in height and seventeen inches (17") in width stating:

NOTICE: THIS AGENCY IS A RECIPIENT OF TAXPAYER FUNDING. IF YOU OBSERVE AN AGENCY DIRECTOR OR EMPLOYEE ENGAGING IN ANY ACTIVITY WHICH YOU CONSIDER TO BE ILLEGAL, IMPROPER, OR WASTEFUL, PLEASE CALL THE STATE COMPTROLLER'S TOLL-FREE HOTLINE: 1-800-232-5454.

The sign shall be on the form prescribed by the Comptroller of the Treasury. The Grantor State Agency shall obtain copies of the sign from the Comptroller of the Treasury, and upon request from the Grantee, provide Grantee with any necessary signs.

### **Public Notice.**

All notices, informational pamphlets, press releases, research reports, signs, and similar public notices prepared and released by the Grantee in relation to this Grant Contract shall include the statement, "This project is funded under a grant contract with the State of Tennessee, Department of Transportation." All notices by the Grantee in relation to this Grant Contract shall be approved by the State.

### **Records.**

The Grantee and any approved subcontractor shall maintain documentation for all charges under this Grant Contract. The books, records, and documents of the Grantee and any approved subcontractor, insofar as they relate to work performed or money received under this Grant Contract, shall be maintained in accordance with applicable Tennessee law. In no case shall the records be maintained for a period of less than five (5) full years from the date of the final payment. The Grantee's records shall be subject to audit at any reasonable time and upon reasonable notice by the Grantor State Agency, the Comptroller of the Treasury, or their duly appointed representatives.

The records shall be maintained in accordance with Governmental Accounting Standards Board (GASB) Accounting Standards or the Financial Accounting Standards Board (FASB) Accounting Standards Codification, as applicable, and any related AICPA Industry Audit and Accounting guides.

In addition, documentation of grant applications, budgets, reports, awards, and expenditures will be maintained in accordance with U.S. Office of Management and Budget's Uniform Administrative Requirements, Cost Principles, and Audit Requirements for Federal Awards.

Grant expenditures shall be made in accordance with local government purchasing policies and procedures and purchasing procedures for local governments authorized under state law.

The Grantee shall also comply with any recordkeeping and reporting requirements prescribed by the Tennessee Comptroller of the Treasury.

The Grantee shall establish a system of internal controls that utilize the COSO Internal Control - Integrated Framework model as the basic foundation for the internal control system. The Grantee shall incorporate any additional Comptroller of the Treasury directives into its internal control system. Any other required records or reports which are not contemplated in the above standards shall follow the format designated by the head of the Grantor State Agency, the Central Procurement Office, or the Commissioner of Finance and Administration of the State of Tennessee.

**Environmental Tobacco Smoke.**

Pursuant to the provisions of the federal “Pro-Children Act of 1994” and the “Children’s Act for Clean Indoor Air of 1995,” Tenn Code Ann. §§39-17-1601 through 1606, the Grantee shall prohibit smoking of tobacco products within any indoor premises in which services are provided to individuals under the age of eighteen (18) years. The Grantee shall post “no smoking” signs in appropriate, permanent sites within such premises. This prohibition shall be applicable during all hours, not just the hours in which children are present. Violators of the prohibition may be subject to civil penalties and fines. This prohibition shall apply to and be made part of any subcontract related to this Grant Contract.

**EXHIBIT C**  
**PROJECT SCHEDULE**

**EXHIBIT D**  
**CONTRACTOR'S BID AND SCHEDULE OF VALUES**

**EXHIBIT E**  
**INSURANCE REQUIREMENTS**

1. GENERAL CONSIDERATIONS

Contractor agrees to the indemnity obligations set forth in the Contract Documents. Nashville MTA reserves the right to participate in the defense of any claim or action that is brought against Nashville MTA as set forth in **Section 20**.

To insure compliance with Nashville MTA’s requirements, Nashville MTA requires each Contractor to carry adequate insurance coverage with a company or companies acceptable to said Nashville MTA.

2. INSURANCE REQUIREMENTS

A. MINIMUM LIMITS OF COVERAGE – Coverage shall be at least to the following minimum limits if checked as provided herein. If Contractor has or obtains primary and umbrella excess policies, there shall be no gap between such policies.

GENERAL LIABILITY

|     |   |             |                              |
|-----|---|-------------|------------------------------|
| (a) | Comprehensive General Liability             |             |                              |
|     | Bodily Injury                               | \$1,000,000 | Ea. Occurrence               |
|     |   | \$1,000,000 | Aggregate Per Project        |
|     | Property Damage                             | \$1,000,000 | Ea. Occurrence               |
|     |   | \$1,000,000 | Aggregate Per Project        |
|     | (or) Combined Single Limit                  | \$1,000,000 | Per Occurrence Per Project   |
| (b) | Premises and Operations Liability           |             | same limits as in (a) above. |
| (c) | Products and Completed Operations Liability |             | same limits as in (a) above. |
| (d) | Contractual Liability                       |             | same limits as in (a) above. |

AUTOMOBILE LIABILITY

|     |   |             |                |
|-----|---|-------------|----------------|
| (e) | Comprehensive Automobile Liability (all owned, hired and non-owned) |             |                |
|     | Bodily Injury   | \$1,000,000 | Ea. Person     |
|     |   | \$1,000,000 | Ea. Occurrence |
|     | Property Damage   | \$1,000,000 | Ea. Occurrence |
|     |   | \$1,000,000 | Aggregate      |
|     | (or) Combined Single Limit  | \$1,000,000 | Per Occurrence |

WORKERS COMPENSATION AND EMPLOYER'S LIABILITY

|     |   |                                   |                |
|-----|---|-----------------------------------|----------------|
| (f) | Worker's Compensation<br>(including compliance with the<br>Jones Act and Longshoremen's and<br>Harbor Worker's Act as applicable)<br>Employer's Liability | Statutory Amount<br><br>\$100,000 | Ea. Occurrence |
| (g) | Builder's Risk Insurance  | \$(Value of Structure)            |                |
| (h) | Other Insurance   | \$(As Required)                   |                |

B. Check if Required:

GENERAL LIABILITY

a. Comprehensive (Commercial) General Liability:  
Contractor shall have and maintain such Bodily Injury Liability Insurance and Property Damage Liability Insurance as shall protect Contractor from Claims for Bodily Injury and Property Damage arising from Contractor's Construction Services under the Contract, whether such operations are conducted by Contractor or Contractor's Agents. The Bodily Injury Liability Insurance shall pay on behalf of the Insured, or Additional Insured, as applicable, all sums up to the limits provided by the policy which the Insured, or Additional Insured, as applicable, shall become legally obligated to pay as damages because of bodily injury, sickness or disease, including death at any time resulting therefrom, sustained by a person other than an employee of Contractor and caused by any occurrence. The Property Damage Liability Insurance shall pay on behalf of the of the Insured, or Additional Insured, as applicable, all sums up to the limits provided by the policy which the Insured, or Additional Insured, as applicable, shall become legally obligated to pay as damages because of injury to, or destruction of property, including the loss of use thereof, caused by any occurrence.

This policy shall cover liability for damage to property caused by blasting or explosion or collapse, or structural injury to any building or structure, or damage to any property below the surface of the ground (Explosion, Collapse and Underground Damage) as applicable.

b. Premises and Operations Liability:  
Contractor shall have and maintain such Premises and Operations Liability Insurance as shall protect Contractor, Nashville MTA and the Covered Entities from liability resulting from the operations under the Contract by Contractor.

c. Products and Completed Operations Liability  
Contractor shall provide such Products and Completed Operations Insurance as shall protect Contractor, Nashville MTA and the Covered Entities from liability arising out of the Contract and including those products involved in the work for which Contractor is responsible.

d. Broad Form Contractual Liability:  
Contractor shall have and maintain such Contractual Liability Insurance as shall protect Contractor from liability resulting from the execution of the Contract by Contractor. If coverage is not provided on the



blanket form basis, a copy of the policy or endorsement providing coverage for contractual liability assumed by Contractor under its Contract with Nashville MTA must be attached to the Certificate of Insurance.

#### AUTOMOBILE LIABILITY

(x) e. Comprehensive (Business) Automobile Liability (all owned, hired and non-owned): Contractor shall have and maintain such Comprehensive (Business) Automobile Liability (all owned, hired, and non-owned) Insurance as shall protect Contractor, and the Covered Entities for Claims arising out of the ownership, operation, maintenance and use of land motor vehicles and trailers intended for use therewith.

#### WORKER'S COMPENSATION AND EMPLOYERS' LIABILITY

(x) f. Contractor shall have and maintain Worker's Compensation Insurance conforming with the requirements of the laws of Tennessee and (if the box is checked) the Jones Act ( ) and the Longshoremen's and Harbor Workers' Compensation Act ( ). In case of any employee or employees are not covered by such laws of Tennessee of the Jones Act or the Longshoremen's and Harbor Workers' Compensation Act, Contractor shall provide Employers' Liability coverage for the protection of such employee or employees.

#### BUILDERS' RISK INSURANCE

(x) g. Builders' Risk Insurance  
Contractor shall have and maintain such Property Insurance upon Contractor's entire work at the site to the completed value thereof. This insurance shall protect the Covered Entities as their interest may appear in the Construction Services and shall insure against the perils of fire and extended coverage, and shall include "all risk" insurance for the physical loss or damage including without duplication of coverage, theft, vandalism and malicious mischief. All Risk Insurance may contain the normal exclusions such as, but not limited to, flood, earthquake, mysterious disappearance, inherent vice, war and nuclear. If Nashville MTA requires coverage for flood or earthquake, specific requirements concerning same are set out hereafter in these specifications. If the Property Insurance contains a co-insurance provision, Contractor shall be responsible for the amount of insurance satisfying the co-insurance amount so as to make the co-insurance clause inoperable. If not covered otherwise, Contractor shall have and maintain during the life of the Contract similar Property Insurance on portions of the work stored off the site or in transit when such portions of the work are to be included in any payment. The Covered Entities, in addition to being Additional Insureds as required above, shall be loss payees.

( ) h. Other Insurance:

#### C. ADDITIONAL INSURANCE REQUIREMENTS:

1. The Certificate of Certificates of Insurance shall contain the following provision, to-wit:

The coverage provided shall not be canceled, reduced in coverage, or allowed to lapse unless and until Nashville MTA receives at least thirty (30) calendar days' advance written notice of same. Said written notice must be delivered to the Contracting Officer and the Director, Insurance and Safety Division, at his office shown as the address of the Certificate Holder below.

2. ( ) If this box is checked, each of the said policies set out above may contain a deductible

feature not in excess of \$ \_\_\_\_\_ per occurrence. If a deductible feature is provided in a policy or policies, Contractor shall be liable for said amount of any claim or loss.

3. During the performance and up to the date of Final Payment, Contractor must effect and maintain insurance hereafter checked as required. The insurance policies in the amounts set forth below shall be primary policies and the insurance companies shall be licensed to do business in Tennessee. Any excess over one million dollars (\$1,000,000) policy may be with either a licensed or non-admitted company provided the non-admitted company is: (1) listed as approved to do business in Tennessee by the Tennessee Department of Insurance, (2) has a Best financial rating of A minus or better, with a policyholder surplus of Roman Numeral X or better, and (3) otherwise acceptable to Nashville MTA.
4. All Comprehensive General Liability policies, Comprehensive Automobile Liability policies and Property Damage policies shall be endorsed to include Nashville MTA and the Covered Entities, defined in **Section 20** of the Contract, as Additional Insureds and this shall be noted on the Certificates of Insurance.
5. All policies must be of the standard form of coverage as filed with and approved by the Commissioner of Insurance for the State of Tennessee or otherwise authorized. Contractor shall not commence work under the Contract until it has obtained all insurance coverages required under this Contract and such insurance has been approved in writing by Nashville MTA.
6. Contractor is required to cover its Contracting Agents, including its subcontractors, with Comprehensive (Commercial) General Liability insurance.
7. The limit "Ea. Person" is the monetary limit applied to each person injured in a given occurrence. The limit "Ea. Occur" is the limit of the total liability for Claims, subject to the limit for "Ea. Person," from one common cause. The word "Aggregate" is the limit of the total liability for all damage of the specified coverage for each annual term of the insurance policy.
8. Contractor is required to have a CERTIFICATE of INSURANCE properly executed by an insurance company or insurance companies authorized to do business in the State of Tennessee.

**EXHIBIT F**  
**CONTRACTOR'S PERFORMANCE AND PAYMENT BONDS**

**EXHIBIT G**  
**DISADVANTAGED BUSINESS UTILIZATION PLAN**

## APPENDIX A

### DAVIS BACON RATES

**NOTICE TO BIDDERS: DAVIS BACON RATES ARE PROVIDED FOR INFORMATION PURPOSES ONLY**

**BIDDER IS RESPONSIBLE FOR VERIFYING DAVIS BACON RATES BY USING:**

**<https://sam.gov/content/home> - WAGE DETERMINATIONS**

**CONTRACTOR MUST PAY APPLICABLE DAVIS BACON RATES THROUGHOUT THE TERM OF THE CONTRACT; CONTRACTOR IS ADVISED THAT RATES MAY CHANGE DURING THE CONTRACT TERM.**

"General Decision Number: TN20240147 01/05/2024

Superseded General Decision Number: TN20230147

State: Tennessee

Construction Type: Highway

Counties: Tennessee Statewide.

HIGHWAY CONSTRUCTION PROJECTS

Note: Contracts subject to the Davis-Bacon Act are generally required to pay at least the applicable minimum wage rate required under Executive Order 14026 or Executive Order 13658. Please note that these Executive Orders apply to covered contracts entered into by the federal government that are subject to the Davis-Bacon Act itself, but do not apply to contracts subject only to the Davis-Bacon Related Acts,

including those set forth at 29 CFR 5.1(a)(1).

|   |   |
|---|---|
| If the contract is entered<br> into on or after January 30,<br> 2022, or the contract is<br> renewed or extended (e.g., an<br> option is exercised) on or<br> after January 30, 2022:<br> <br> <br> <br> <br> | . Executive Order 14026<br> generally applies to the<br> contract.<br> . The contractor must pay<br> all covered workers at<br> least \$17.20 per hour (or<br> the applicable wage rate<br> listed on this wage<br> determination, if it is<br> higher) for all hours<br> spent performing on the<br> contract in 2024. |
| If the contract was awarded on<br> or between January 1, 2015 and<br> January 29, 2022, and the<br> contract is not renewed or<br> extended on or after January<br> 30, 2022:<br> <br> <br> <br> <br>         | . Executive Order 13658<br> generally applies to the<br> contract.<br> . The contractor must pay all<br> covered workers at least<br> \$12.90 per hour (or the<br> applicable wage rate listed<br> on this wage determination,<br> if it is higher) for all<br> hours spent performing on<br> that contract in 2024.    |

The applicable Executive Order minimum wage rate will be adjusted annually. If this contract is covered by one of the Executive Orders and a classification considered necessary for performance of work on the contract does not appear on this wage determination, the contractor must still submit a conformance request.

Additional information on contractor requirements and worker protections under the Executive Orders is available at <http://www.dol.gov/whd/govcontracts>.

|                     |                  |
|---------------------|------------------|
| Modification Number | Publication Date |
| 0                   | 01/05/2024       |

SUTN2016-001 07/13/2016

|                                    | Rates    | Fringes |
|------------------------------------|----------|---------|
| BRICKLAYER.....                    | \$ 14.26 | **      |
| CARPENTER.....                     | \$ 17.52 |         |
| CEMENT MASON/CONCRETE FINISHER.... | \$ 15.55 | **      |
| ELECTRICIAN.....                   | \$ 24.08 |         |
| IRONWORKER                         |          |         |
| Reinforcing.....                   | \$ 16.29 | **      |
| Structural.....                    | \$ 16.89 | **      |
| LABORER                            |          |         |
| Common/Unskilled.....              | \$ 13.11 | **      |
| Skilled                            |          |         |
| Air Tool Operator,                 |          |         |
| Asphalt Raker, Chain Saw           |          |         |
| Operator, Concrete Mixer           |          |         |
| (less than 1 yd),                  |          |         |
| Concrete Rubber, Edger,            |          |         |
| Fence Erector, Form                |          |         |
| Setter (steel), Guard              |          |         |
| Rail Erector, Mechanic's           |          |         |
| Tender (tire changer or            |          |         |
| oiler), Mortar Mixer,              |          |         |
| Nozzleman or Gun Operator          |          |         |
| (gunite), Pipelayer,               |          |         |
| Sign Erector.....                  | \$ 15.27 | **      |
| PAINTER (INCLUDES SANDBLASTER).... | \$ 26.36 |         |
| POWER EQUIPMENT OPERATOR:          |          |         |
| GROUP 1                            |          |         |
| Backhoe/Hydraulic                  |          |         |
| Excavator (3/4 yd &                |          |         |
| over), Crane (less than            |          |         |
| 20 Tons), End Loader (3            |          |         |
| yd & over), Motor Patrol           |          |         |
| (finish), Piledriver,              |          |         |
| Dragline.....                      | \$ 19.14 |         |
| GROUP 1A                           |          |         |
| Drill Operator (Caisson)....       | \$ 25.26 |         |
| Farm Tractor Operator              |          |         |
| (Power Broom).....                 | \$ 13.50 | **      |

GROUP 2

Backhoe/Hydraulic  
Excavator (less than 3/4  
yd), Bulldozer or Push  
Dozer, End Loader (less  
than 3 yd), Motor Patrol  
(rough), Tractor  
(crawler/ utility), Truck  
Driver (Heavy Duty, Off  
Road) Scraper, Shovel, or  
Trenching Machine.....\$ 17.08 \*\*

GROUP 3

Asphalt Paver, Concrete  
Finishing Machine,  
Concrete Paver, Scale,  
Spreader (self-  
propelled), Concrete  
Grinder, Asphalt Milling  
Machine, Boring Machine  
(horizontal).....\$ 17.75

GROUP 4

Bobcat, Central Mining  
Plant, Concrete Pump,  
Concrete Saw, Curb  
Machine (automatic or  
manual), Dozer or Loader  
(stockpile), Drill  
(piling), Mulcher or  
Seeder, Rock Drill (truck  
mounted), Roller  
(asphalt), Roller  
(compaction self-  
propelled), Soil  
Stabilization Machine,  
Tractor (boom and hoist),  
Bituminous Distributor  
Machine, pump, Track  
Drill, Striping Machine....\$ 16.48 \*\*  
Heavy Duty Mechanic.....\$ 20.33  
Light Duty Mechanic.....\$ 19.53  
Sweeping Machine (Vacuum)  
Operator.....\$ 15.56 \*\*

GROUP 5

Crane (over 20 Tons).....\$ 20.44

TRUCK DRIVER

2 axles.....\$ 15.36 \*\*  
3-4 axles.....\$ 14.86 \*\*  
5 or more axles.....\$ 16.27 \*\*

---

WELDERS - Receive rate prescribed for craft performing operation to which welding is incidental.

---

\*\* Workers in this classification may be entitled to a higher minimum wage under Executive Order 14026 (\$17.20) or 13658 (\$12.90). Please see the Note at the top of the wage determination for more information. Please also note that the minimum wage requirements of Executive Order 14026 are not currently being enforced as to any contract or subcontract to which the states of Texas, Louisiana, or Mississippi, including their agencies, are a party.

Note: Executive Order (EO) 13706, Establishing Paid Sick Leave for Federal Contractors applies to all contracts subject to the Davis-Bacon Act for which the contract is awarded (and any solicitation was issued) on or after January 1, 2017. If this contract is covered by the EO, the contractor must provide employees with 1 hour of paid sick leave for every 30 hours they work, up to 56 hours of paid sick leave each year. Employees must be permitted to use paid sick leave for their own illness, injury or other health-related needs, including preventive care; to assist a family member (or person who is like family to the employee) who is ill, injured, or has other health-related needs, including preventive care; or for reasons resulting from, or to assist a family member (or person who is like family to the employee) who is a victim of, domestic violence, sexual assault, or stalking. Additional information on contractor requirements and worker protections under the EO is available at <https://www.dol.gov/agencies/whd/government-contracts>.

Unlisted classifications needed for work not included within the scope of the classifications listed may be added after award only as provided in the labor standards contract clauses (29CFR 5.5 (a) (1) (iii)).

---



The body of each wage determination lists the classification and wage rates that have been found to be prevailing for the cited type(s) of construction in the area covered by the wage determination. The classifications are listed in alphabetical order of "identifiers" that indicate whether the particular rate is a union rate (current union negotiated rate for local), a survey rate (weighted average rate) or a union average rate (weighted union average rate).

#### Union Rate Identifiers

A four-letter classification abbreviation identifier enclosed in dotted lines beginning with characters other than "SU" or "UAVG" denotes that the union classification and rate were prevailing for that classification in the survey. Example: PLUM0198-005 07/01/2014. PLUM is an abbreviation identifier of the union which prevailed in the survey for this classification, which in this example would be Plumbers. 0198 indicates the local union number or district council number where applicable, i.e., Plumbers Local 0198. The next number, 005 in the example, is an internal number used in processing the wage determination. 07/01/2014 is the effective date of the most current negotiated rate, which in this example is July 1, 2014.

Union prevailing wage rates are updated to reflect all rate changes in the collective bargaining agreement (CBA) governing this classification and rate.

#### Survey Rate Identifiers

Classifications listed under the "SU" identifier indicate that no one rate prevailed for this classification in the survey and the published rate is derived by computing a weighted average rate based on all the rates reported in the survey for that classification. As this weighted average rate includes all rates reported in the survey, it may include both union and non-union rates. Example: SULA2012-007 5/13/2014. SU indicates the rates are survey rates based on a weighted average calculation of rates and are not majority rates. LA indicates the State of Louisiana. 2012 is the year of survey on which these classifications and rates are based. The next number, 007 in the example, is an internal number used in producing the wage determination. 5/13/2014 indicates the survey completion date for the classifications and rates under that identifier.

Survey wage rates are not updated and remain in effect until a new survey is conducted.

#### Union Average Rate Identifiers

Classification(s) listed under the UAVG identifier indicate that no single majority rate prevailed for those classifications; however, 100% of the data reported for the classifications was union data. EXAMPLE: UAVG-OH-0010 08/29/2014. UAVG indicates that the rate is a weighted union average rate. OH indicates the state. The next number, 0010 in the example, is an internal number used in producing the wage determination. 08/29/2014 indicates the survey completion date for the classifications and rates under that identifier.

A UAVG rate will be updated once a year, usually in January of each year, to reflect a weighted average of the current negotiated/CBA rate of the union locals from which the rate is based.

---

#### WAGE DETERMINATION APPEALS PROCESS

1.) Has there been an initial decision in the matter? This can be:

- \* an existing published wage determination
- \* a survey underlying a wage determination
- \* a Wage and Hour Division letter setting forth a position on a wage determination matter
- \* a conformance (additional classification and rate) ruling

On survey related matters, initial contact, including requests for summaries of surveys, should be with the Wage and Hour National Office because National Office has responsibility for the Davis-Bacon survey program. If the response from this initial contact is not satisfactory, then the process described in 2.) and 3.) should be followed.

With regard to any other matter not yet ripe for the formal process described here, initial contact should be with the Branch of Construction Wage Determinations. Write to:

Branch of Construction Wage Determinations  
Wage and Hour Division  
U.S. Department of Labor  
200 Constitution Avenue, N.W.  
Washington, DC 20210

2.) If the answer to the question in 1.) is yes, then an interested party (those affected by the action) can request review and reconsideration from the Wage and Hour Administrator (See 29 CFR Part 1.8 and 29 CFR Part 7). Write to:

Wage and Hour Administrator  
U.S. Department of Labor  
200 Constitution Avenue, N.W.  
Washington, DC 20210

The request should be accompanied by a full statement of the interested party's position and by any information (wage payment data, project description, area practice material, etc.) that the requestor considers relevant to the issue.

3.) If the decision of the Administrator is not favorable, an interested party may appeal directly to the Administrative Review Board (formerly the Wage Appeals Board). Write to:

Administrative Review Board  
U.S. Department of Labor  
200 Constitution Avenue, N.W.  
Washington, DC 20210

4.) All decisions by the Administrative Review Board are final.

=====

END OF GENERAL DECISION"

# **APPENDIX B**

## **DRAWINGS AND SPECIFICATIONS**

# MYATT PARKING LOTS REHABILITATION

## WeGo PUBLIC TRANSIT

### FACILITIES IMPROVEMENTS

#### 430 MYATT DRIVE, NASVHILLE, TN 37115

#### COUNCIL DISTRICT

#### 100% SUBMITTAL

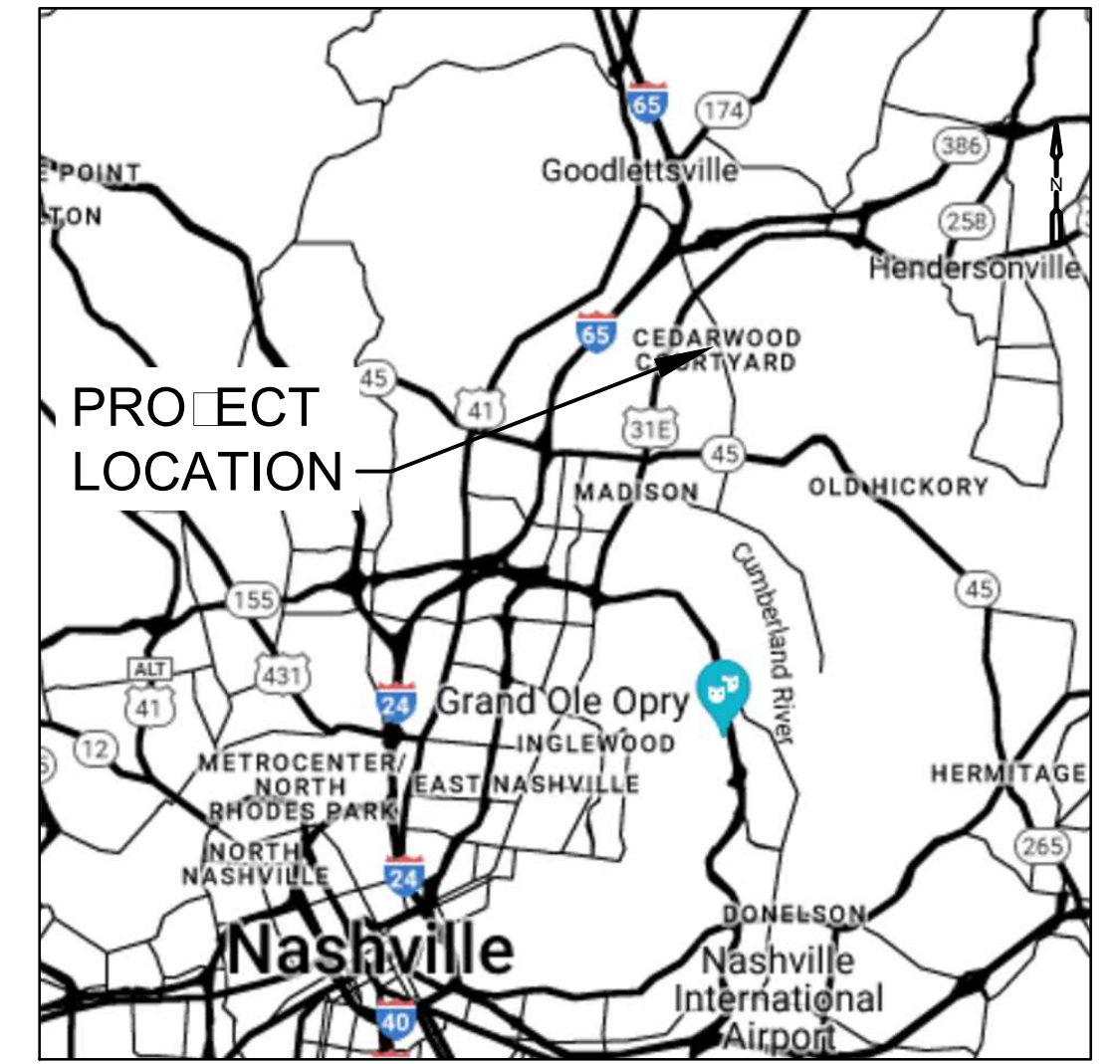

LOCATION MAP

| DRAWING CONTENTS             |  |
|------------------------------|--|
| C - 0                        | COVER SHEET                            |
| G - 1                        | GENERAL NOTES AND ESTIMATED QUANTITIES |
| <input type="checkbox"/> - 1 | TYPICAL SECTIONS                       |
| C - 1                        | DEMOLITION, SURVEY AND EROSION CONTROL |
| C - 2                        | SITE LAYOUT PLAN - CDL LOTS            |
| C - 3                        | PAVEMENT DELINEATION - CDL LOTS        |
| C - 4                        | CONSTRUCTION DETAILS                   |
| C - 5                        | CONSTRUCTION STAGING                   |

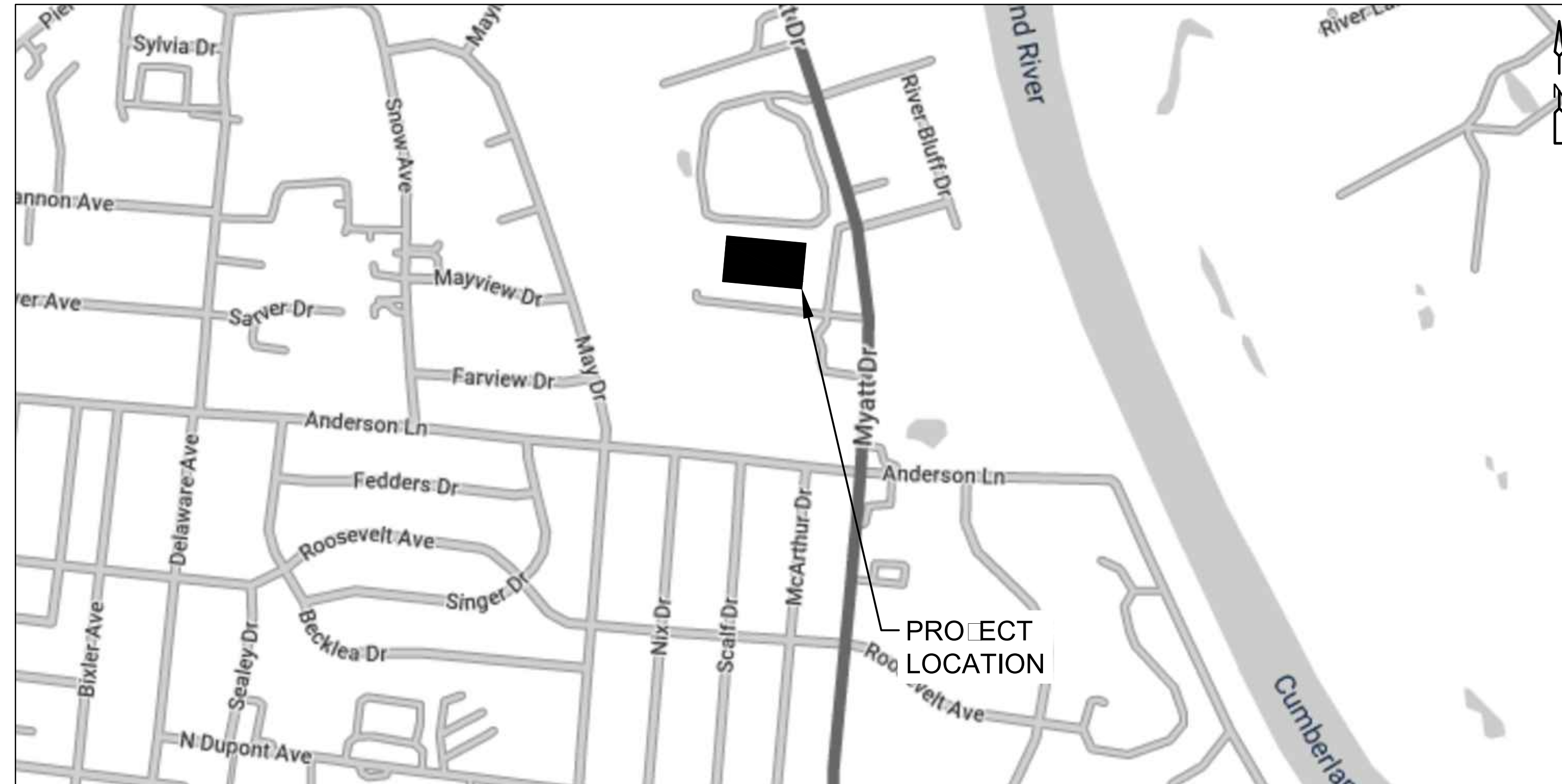

VICINITY MAP

**OWNER INFORMATION:**

WEGO PUBLIC TRANSIT  
430 MYATT DRIVE  
NASHVILLE, TN 37115

WEGO FACILITIES MANAGER  
PATRICK HESTER  
615-351-7113  
PATRICK.HESTER@NASHVILLE.GOV

DIRECTOR OF OPERATIONS  
CAROLYN RIGGS - FARRAR  
CAROLYN.RIGGS-FARRAR@NASHVILLE.GOV

**NDOT**

CHIEF ENGINEER  
BRAD FREEBEE, PE  
615 - 62 - 5000

**ENGINEER OF RECORD**

CDM SMITH  
210 25TH AVE N, SUITE 1102  
NASHVILLE, TN 37203  
JORGE RENTERIA, PE  
615 - 340 - 6455  
RENERIA@CDMSMITH.COM

**WATER & SEWER:**

METRO WATER & SEWER-MWS  
NASHVILLE, TN  
615.62.4600

MADISON SUBURBAN UTILITY  
MADISON, TN  
615.66.3201

**ELECTRIC:**

NASHVILLE ELECTRIC SERVICE  
NASHVILLE, TN  
615.736.6000

**UTILITY INFORMATION**

**NATURAL GAS:**

PIEDMONT NATURAL GAS  
(NASHVILLE GAS)  
NASHVILLE, TN  
615.752.7504

**LANDLINE PHONE/CATV/FIBER OPTIC:**

AT&T DISTRIBUTION  
270.71.2112

COMCAST - METRO CENTER  
NASHVILLE, TN  
615.244.7462

**LANDLINE PHONE/CATV/FIBER OPTIC:**

MCI  
NASHVILLE, TN  
615.340.2800

ERVIN CABLE CONSTRUCTION  
NASHVILLE, TN  
270.614.1200

**TDOT STANDARD DRAWINGS (NOT PRINTED WITH PLANS)**

| DRAWING        | TITLE                                  | REVISION DATE |
|----------------|--|---------------|
| RP - D - 15    | DETAILS OF STANDARD CONCRETE DRIVEWAYS | 6/15/21       |
| EC - STR - 37  | SEDIMENT TUBE                          | 6/10/14       |
| EC - STR - 37A | CURB INLET PROTECTION TYPE 3 & 4       | 11/12         |



© 2024 CDM SMITH ALL RIGHTS RESERVED. REUSE OF DOCUMENTS: THESE DOCUMENTS AND DESIGNS PROVIDED BY PROFESSIONAL SERVICE, INCORPORATED HEREIN, ARE THE PROPERTY OF CDM SMITH AND ARE NOT TO BE USED, IN WHOLE OR PART, FOR ANY OTHER PROJECT WITHOUT THE WRITTEN AUTHORIZATION OF CDM SMITH.

| REV. NO. | DATE | DRWN | CHKD | REMARKS |
|----------|------|------|------|---------|
|          |      |      |      |         |

DESIGNED BY: JORGE RENTERIA  
DRAWN BY: CARLOS SILVA  
SHEET CHK'D BY: \_\_\_\_\_  
CROSS CHK'D BY: \_\_\_\_\_  
APPROVED BY: \_\_\_\_\_  
DATE: AUGUST 2024



WeGo PUBLIC TRANSIT  
MYATT PARKING LOTS REHABILITATION

COVER SHEET  
SHEET NO.  
C-0

DRAWING SCALE: N.T.S.  
PROJECT NO: 289548  
FILE NAME: C-0.dwg



© 2024 CDM SMITH ALL RIGHTS RESERVED. REUSE OF DOCUMENTS: THESE DOCUMENTS AND DESIGNS PROVIDED BY PROFESSIONAL SERVICE, INCORPORATED HEREIN, ARE THE PROPERTY OF CDM SMITH AND ARE NOT TO BE USED, IN WHOLE OR PART, FOR ANY OTHER PROJECT WITHOUT THE WRITTEN AUTHORIZATION OF CDM SMITH.

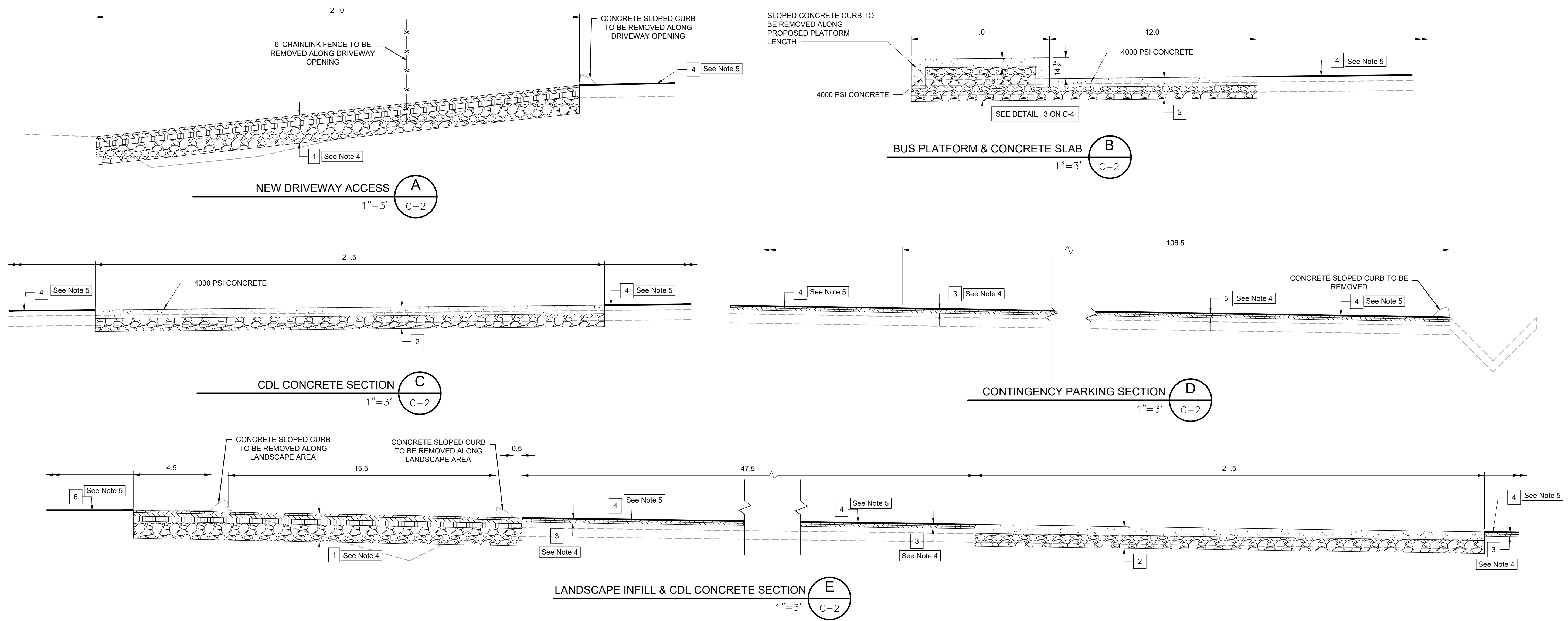

**LEGEND:**

- 411-D- ASPHALT CONCRETE
- 307-BM2- ASPHALT CONCRETE
- 307-A- ASPHALT CONCRETE
- CONCRETE PAVEMENT
- BASE STONE

**PAVEMENT STRUCTURAL SECTION:**

- 1 1.5" 411-D-AC  
2.5" 307-BM2-AC  
3.5" 307-A-AC  
12" AGGREGATE BASE
- 2 6" CONCRETE PAVEMENT  
" BASE TYPE "B" GRADE "B"
- 3 3" GRIND  
1.5" 411-D-AC  
1.5" 307-BM2-AC
- 4 SEAL COAT

**NOTES:**

1. REFER TO LAYOUT SHEETS FOR CURB AND FENCE LOCATIONS.
2. TYPICAL SECTIONS SHALL BE COORDINATED WITH LAYOUT PLANS. IF THERE ARE ANY DISCREPANCIES BETWEEN THE LIMIT SHOWN ON THE TYPICAL SECTIONS AND LAYOUT SHEETS, THE LAYOUT SHEETS WILL GOVERN.
3. REFER TO PAVEMENT DELINEATION PLAN FOR PARKING LOT STRIPPING.
4. USE TACK COAT AT 0.10 GAL SY BETWEEN ASPHALTIC SURFACE COURSE AND ASPHALTIC BINDER COAT. USE PRIMER COAT AT 0.30 GAL SY BETWEEN AGGREGATE BASE AND ASPHALTIC BINDER COURSE.
5. RUBBERIZED ASPHALT FOR SEAL COAT 0.22 GAL SY. CRACK SEALING LABOR AND MATERIALS ARE INCLUDED IN THE UNIT PRICE FOR THIS ITEM.

| REV. NO. | DATE | DRWN | CHKD | REMARKS |
|----------|------|------|------|---------|
|          |      |      |      |         |

DESIGNED BY: JORGE RENTERIA  
 DRAWN BY: CARLOS SILVA  
 SHEET CHK'D BY: \_\_\_\_\_  
 CROSS CHK'D BY: \_\_\_\_\_  
 APPROVED BY: \_\_\_\_\_  
 DATE: AUGUST 2024

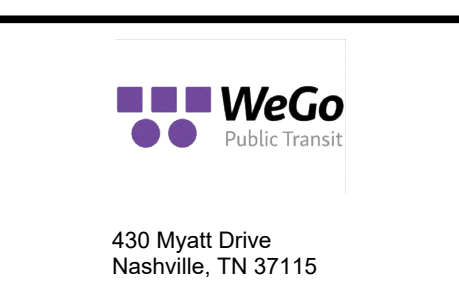

WeGo PUBLIC TRANSIT  
**MYATT PARKING LOTS REHABILITATION**

**TYPICAL SECTIONS**

DRAWING SCALE: 1" = 3'  
 PROJECT NO: 289548  
 FILE NAME: X-1  
 SHEET NO.  
**-1**

© 2024 CDM SMITH ALL RIGHTS RESERVED. REUSE OF DOCUMENTS: THESE DOCUMENTS AND DESIGNS PROVIDED BY PROFESSIONAL SERVICE, INCORPORATED HEREIN, ARE THE PROPERTY OF CDM SMITH AND ARE NOT TO BE USED, IN WHOLE OR PART, FOR ANY OTHER PROJECT WITHOUT THE WRITTEN AUTHORIZATION OF CDM SMITH.

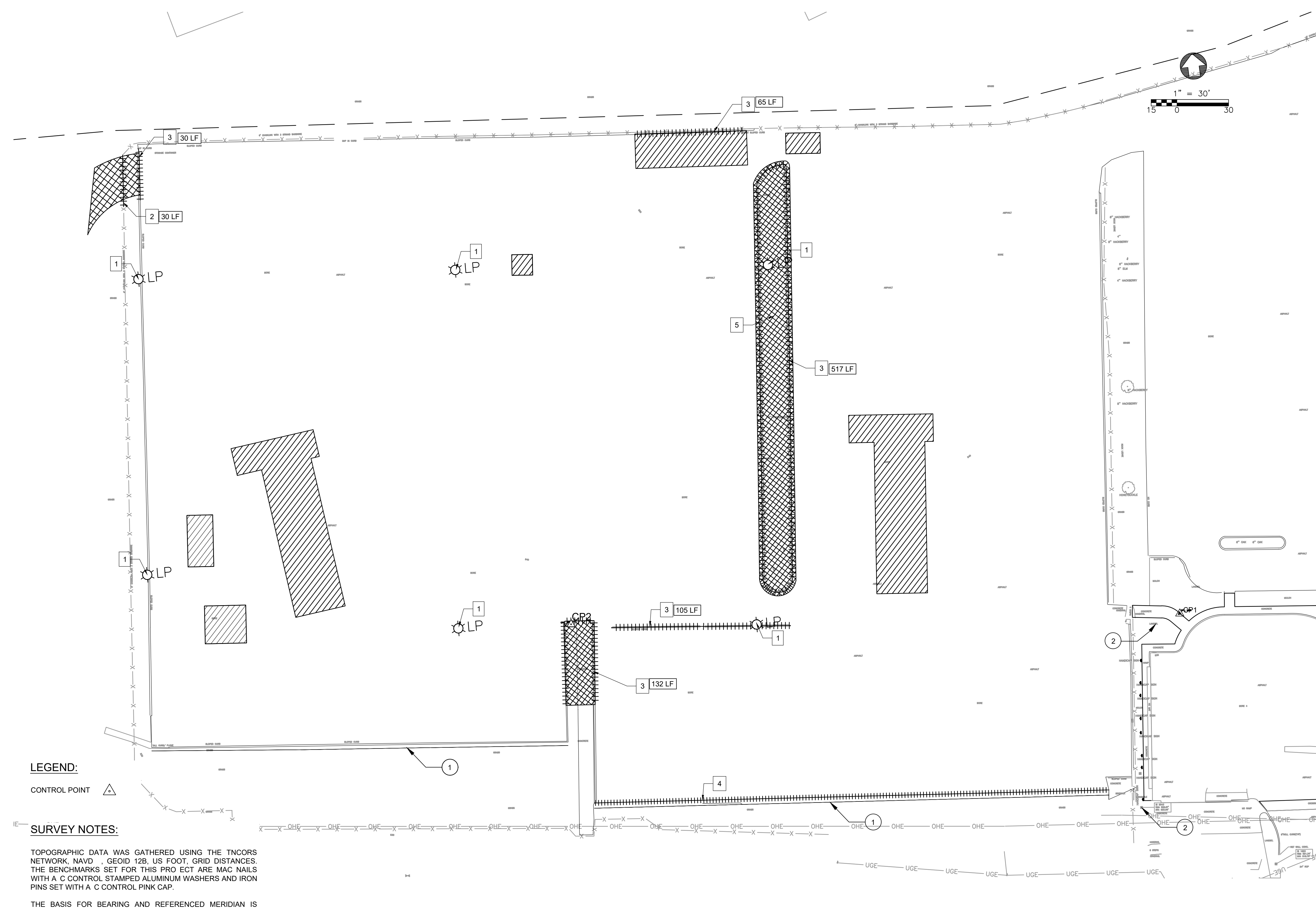

**DEMOLITION NOTES:**

- 1 PROTECT FACILITY IN PLACE
- 2 REMOVE FENCE
- 3 REMOVE CURB
- 4 RESET CONCRETE WHEEL STOPS
- 5 REMOVE TREE

**EROSION CONTROL NOTES:**

- 1 SEDIMENT TUBE
- 2 INLET PROTECTION

**LEGEND:**

- REMOVE CURB, CHAIN LINK FENCE, SPEED BUMP ++++++
- REMOVE TREE (INCLUDING STUMP)
- REMOVAL OF AC CONCRETE [diagonal hatching]
- REMOVAL OF LANDSCAPE GRASS CONCRETE AREA [cross-hatching]

**CONTROL POINTS:**

- CP1 N:707333.07, E:1765016.75, : 530.10  
NAIL W ALUM A C CONTROL WASHER
- CP2 N:7075 7.04, E:1764572. 0, :540.53  
IRON PIN WITH PINK A C CONTROL CAP

**SURVEY LEGEND :**

- ADA STRIPING
- BOLLARD
- COMM COMMUNICATION
- COMMUNICATIONS BO
- COMM. LINE: UNDERGROUND
- CONC CONCRETE
- CMP CORRUGATED METAL PIPE
- CPP CORRUGATED PLASTIC PIPE
- ELECTRICAL BO
- ELECTRICAL MANHOLE
- ELEC. LINE: OVERHEAD
- ELEC. LINE: UNDERGROUND
- FENCE: CHAINLINK
- FIRE HYDRANT
- FORCE MAIN (SAN.)
- GAS LINE
- GAS METER
- GAS VALVE
- GUY WIRE
- GUY WIRE FOR POWER POLE
- INVERT
- LIGHT POLE
- MAG NAIL & WASHER FOUND
- POWER POLE
- RAILROAD CENTERLINE
- REINFORCED CONCRETE PIPE
- RIGHT-OF-WAY
- SANITARY SEWER LINE
- SANITARY SEWER MANHOLE
- SIDEWALK
- STORM DRAIN GRATE INLET
- STORM DRAIN LINE
- STORM DRAIN MANHOLE
- UTILITY MARKER
- VITRIFIED CLAY PIPE
- WATER LINE
- WATER METER
- WATER VALVE

**LEGEND:**

- CONTROL POINT

**SURVEY NOTES:**

TOPOGRAPHIC DATA WAS GATHERED USING THE TNCORS NETWORK, NAVD 83, GEOID 12B, US FOOT, GRID DISTANCES. THE BENCHMARKS SET FOR THIS PROJECT ARE MAC NAILS WITH A C CONTROL STAMPED ALUMINUM WASHERS AND IRON PINS SET WITH A C CONTROL PINK CAP.

THE BASIS FOR BEARING AND REFERENCED MERIDIAN IS FROM TNCORS SPC TN DATUM, GEOID 12B, GRID DISTANCES, US SURVEY FOOT.

|                             |
|-----------------------------|
| DESIGNED BY: JORGE RENTERIA |
| DRAWN BY: CARLOS SILVA      |
| SHEET CHK'D BY:             |
| CROSS CHK'D BY:             |
| APPROVED BY:                |
| DATE: AUGUST 2024           |

DATE: AUGUST 2024

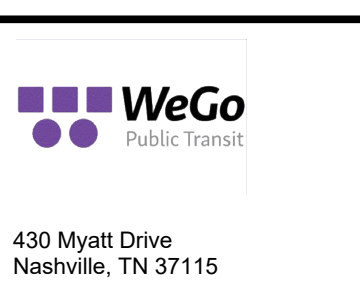

WeGo PUBLIC TRANSIT  
MYATT PARKING LOTS REHABILITATION

DEMOLITION, SURVEY & EROSION CONTROL

DRAWING SCALE: 1" = 30'  
PROJECT NO: 289548  
FILE NAME: C-1.dwg  
SHEET NO.  
**C-1**



© 2024 CDM SMITH ALL RIGHTS RESERVED. REUSE OF DOCUMENTS: THESE DOCUMENTS AND DESIGNS PROVIDED BY PROFESSIONAL SERVICE, INCORPORATED HEREIN, ARE THE PROPERTY OF CDM SMITH AND ARE NOT TO BE USED, IN WHOLE OR PART, FOR ANY OTHER PROJECT WITHOUT THE WRITTEN AUTHORIZATION OF CDM SMITH.

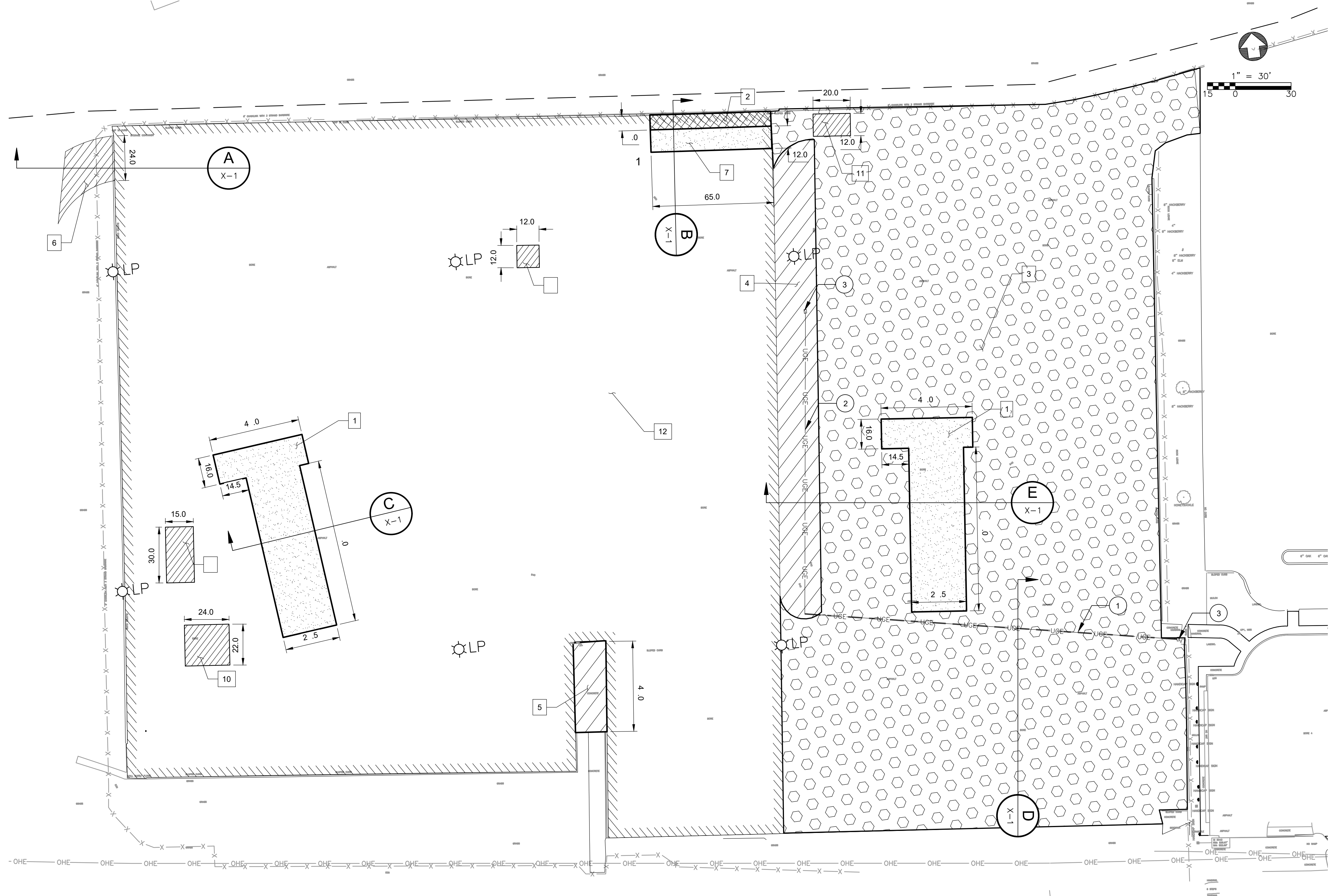

**CONSTRUCTION NOTES:**

- 1 CDL SKILL CAROUSEL  
APPRO AREA 376.0 SQ YD
- 2 BUS PLATFORM  
APPRO AREA 5.0 SQ YD
- 3 PARKING LOT B - CDL TRAINING & CONTINGENCY FLEET PARKING  
APPRO AREA .055.0 SQ YD
- 4 LANDSCAPE ISLAND TO BE REMOVED  
APPRO AREA 621.0 SQ YD
- 5 SIDEWALK TO BE REMOVED  
APPRO AREA 5.0 SQ YD
- 6 NEW DRIVEWAY ACCESS  
APPRO AREA 5.0 SQ YD
- 7 BUS PLATFORM SLAB  
APPRO AREA 7.0 SQ YD
- DIGOUT SECTION  
APPRO AREA 16.0 SQ YD
- DIGOUT SECTION  
APPRO AREA 50.0 SQ YD
- 10 DIGOUT SECTION  
APPRO AREA 5.0 SQ YD
- 11 DIGOUT SECTION  
APPRO AREA 27.0 SQ YD
- 12 PARKING LOT A SEAL COAT SECTION  
(NOT INCLUDING CONCRETE AREAS)  
APPRO AREA 14,045.0 SQ YD

**PAVEMENT REHABILITATION APPROACH**

- 3" GRIND (REMOVAL OF AC)  
1.5" 411 - D  
1.5" 307 - BM2
- 6" CONCRETE PAVEMENT  
" BASE TYPE B GRADE B
- 14 1/2" CONCRETE PLATFORM (SEE DETAILS 3 & 4 ON SHEET C-4)
- 1.5" 411 - D - AC  
2.5" 307 - BM2 - AC  
3.5" 307 - A - AC  
12" AGGREGATE BASE
- SEAL COAT

**GENERAL NOTES:**

- 1 TRENCH ON E 1ST. ASPHALT. SEE DETAIL 1 ON C-4
- 2 TRENCH ON E 1ST. LANDSCAPE AREA. SEE DETAIL 2 ON C-4
- 3 INSTALL TRAFFIC RATED PULLBO 24" 36"

| REV. NO. | DATE | DRWN | CHKD | REMARKS |
|----------|------|------|------|---------|
|          |      |      |      |         |
|          |      |      |      |         |
|          |      |      |      |         |

DESIGNED BY: JORGE RENTERIA  
 DRAWN BY: CARLOS SILVA  
 SHEET CHK'D BY: \_\_\_\_\_  
 CROSS CHK'D BY: \_\_\_\_\_  
 APPROVED BY: \_\_\_\_\_  
 DATE: AUGUST 2024



WeGo PUBLIC TRANSIT  
**MYATT PARKING LOTS REHABILITATION**

SITE LAYOUT PLAN - CDL LOTS

DRAWING SCALE: 1" = 30"  
 PROJECT NO: 289548  
 FILE NAME: C-2.dwg  
 SHEET NO.  
**C-2**

© 2024 CDM SMITH ALL RIGHTS RESERVED. REUSE OF DOCUMENTS: THESE DOCUMENTS AND DESIGNS PROVIDED BY PROFESSIONAL SERVICE, INCORPORATED HEREIN, ARE THE PROPERTY OF CDM SMITH AND ARE NOT TO BE USED, IN WHOLE OR PART, FOR ANY OTHER PROJECT WITHOUT THE WRITTEN AUTHORIZATION OF CDM SMITH.

**SIGNAGE AND STRIPING NOTES:**

- 1 INSTALL 4" WIDE SOLID WHITE PAINT
- 2 INSTALL 4" WIDE DOTTED WHITE PAINT
- 3 RESET BUS CONCRETE WHEEL STOP

**SURVEY MARKERS**

| NAME | NORTHING  | EASTING    |
|------|-----------|------------|
| SM1  | 707863.03 | 1764375.26 |
| SM2  | 707869.18 | 1764440.97 |
| SM3  | 707823.20 | 1764378.99 |
| SM4  | 707829.35 | 1764444.70 |
| SM5  | 707854.44 | 1764497.34 |
| SM6  | 707817.73 | 1764480.69 |
| SM7  | 707733.10 | 1764488.61 |
| SM8  | 707720.03 | 1764509.93 |
| SM9  | 707724.17 | 1764394.03 |
| SM10 | 707728.37 | 1764438.84 |
| SM11 | 707712.22 | 1764395.15 |
| SM12 | 707716.42 | 1764439.96 |
| SM13 | 707625.96 | 1764417.79 |
| SM14 | 707627.08 | 1764429.74 |
| SM15 | 707627.22 | 1764431.23 |
| SM16 | 707628.34 | 1764443.18 |
| SM17 | 707834.54 | 1764762.05 |
| SM18 | 707826.88 | 1764827.60 |
| SM19 | 707794.84 | 1764757.15 |
| SM20 | 707787.13 | 1764823.17 |
| SM21 | 707772.65 | 1764856.79 |
| SM22 | 707799.35 | 1764880.06 |
| SM23 | 707688.22 | 1764846.92 |
| SM24 | 707665.27 | 1764864.37 |
| SM25 | 707694.76 | 1764752.04 |
| SM26 | 707689.53 | 1764796.74 |
| SM27 | 707682.84 | 1764750.65 |
| SM28 | 707677.62 | 1764795.34 |
| SM29 | 707593.75 | 1764754.83 |
| SM30 | 707592.36 | 1764766.75 |
| SM31 | 707592.18 | 1764768.24 |
| SM32 | 707590.79 | 1764780.16 |

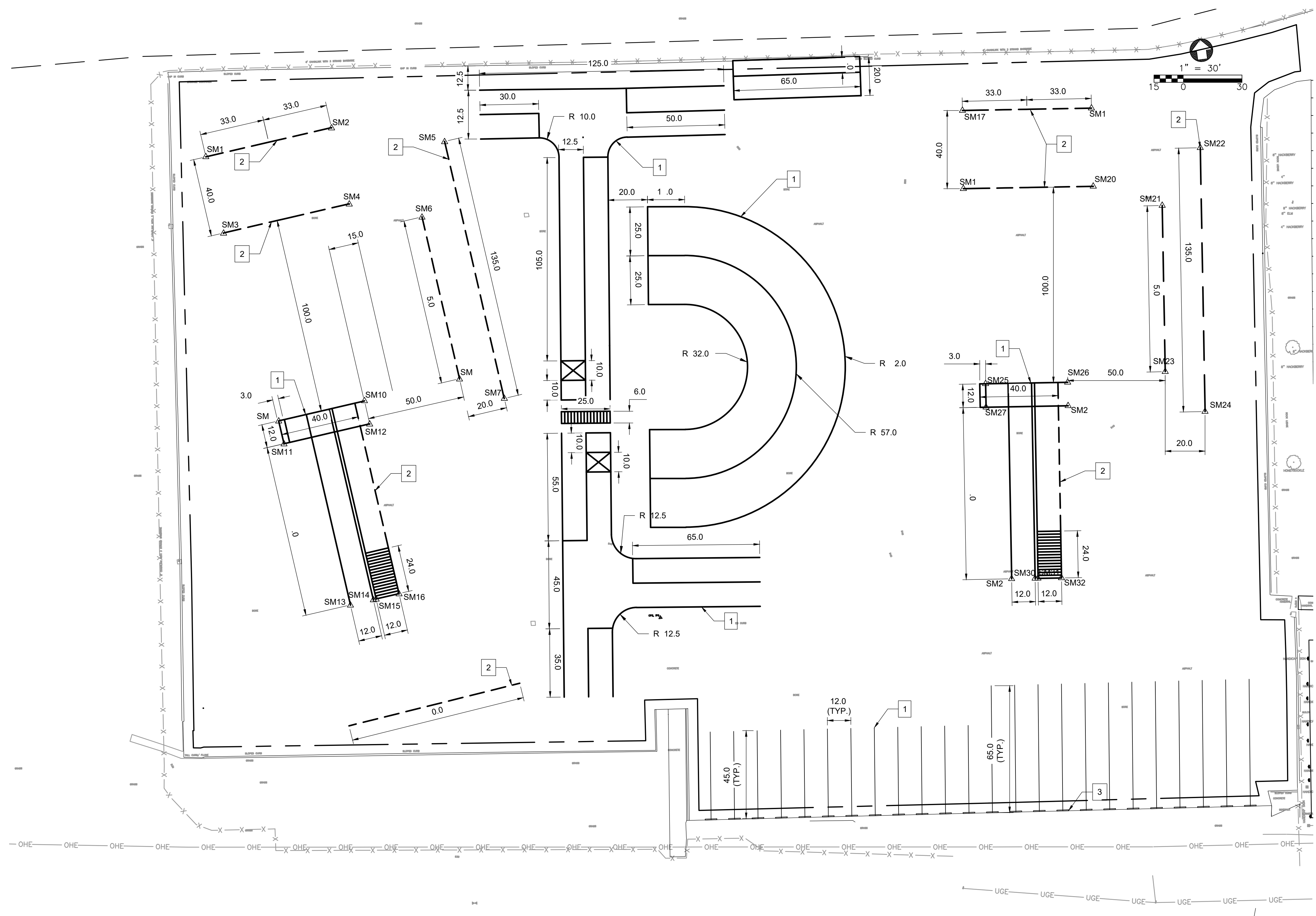

| REV. NO. | DATE   | DRWN | CHKD | REMARKS                                   |
|----------|--------|------|------|---|
| 1        | 7/1/24 | C S  | R    | UPDATED TO SHOW NEW LOCATION OF PLATFORM. |

DESIGNED BY: JORGE RENTERIA  
 DRAWN BY: CARLOS SILVA  
 SHEET CHK'D BY:  
 CROSS CHK'D BY:  
 APPROVED BY:  
 DATE: AUGUST 2024

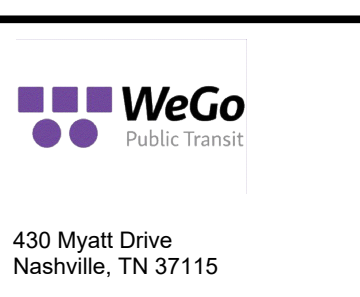

WeGo PUBLIC TRANSIT  
**MYATT PARKING LOTS REHABILITATION**

**PAVEMENT DELINEATION - CDL LOTS**

DRAWING SCALE: 1" = 30'  
 PROJECT NO: 289548  
 FILE NAME: C-3.dwg  
 SHEET NO.  
**C-3**

© 2024 CDM SMITH ALL RIGHTS RESERVED. REUSE OF DOCUMENTS: THESE DOCUMENTS AND DESIGNS PROVIDED BY PROFESSIONAL SERVICE, INCORPORATED HEREIN, ARE THE PROPERTY OF CDM SMITH AND ARE NOT TO BE USED, IN WHOLE OR PART, FOR ANY OTHER PROJECT WITHOUT THE WRITTEN AUTHORIZATION OF CDM SMITH.

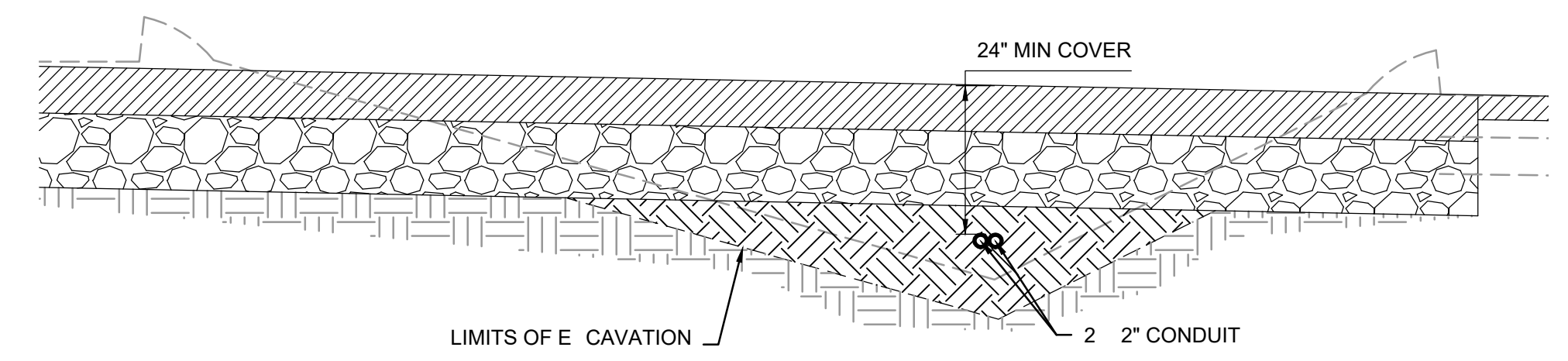

**CONDUIT ON LANDSCAPE INFILL**  
 1  
 1"=2'  
 C-2

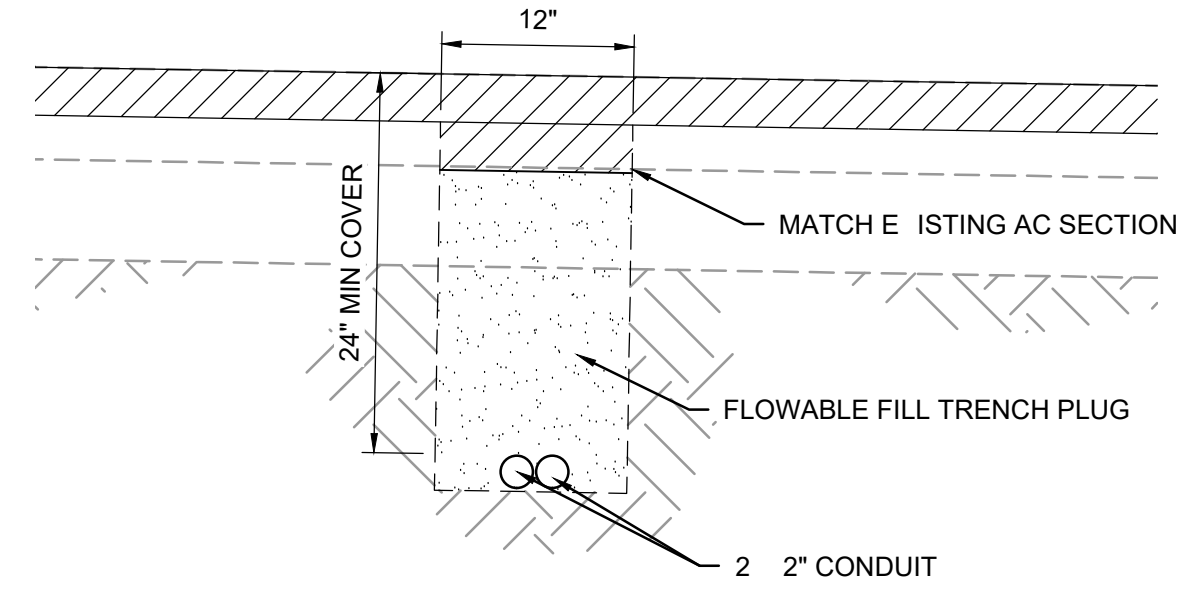

**TRENCH ON E ISTING ASPHALT SECTION - LOT "B"**  
 2  
 1"=1'  
 C-2

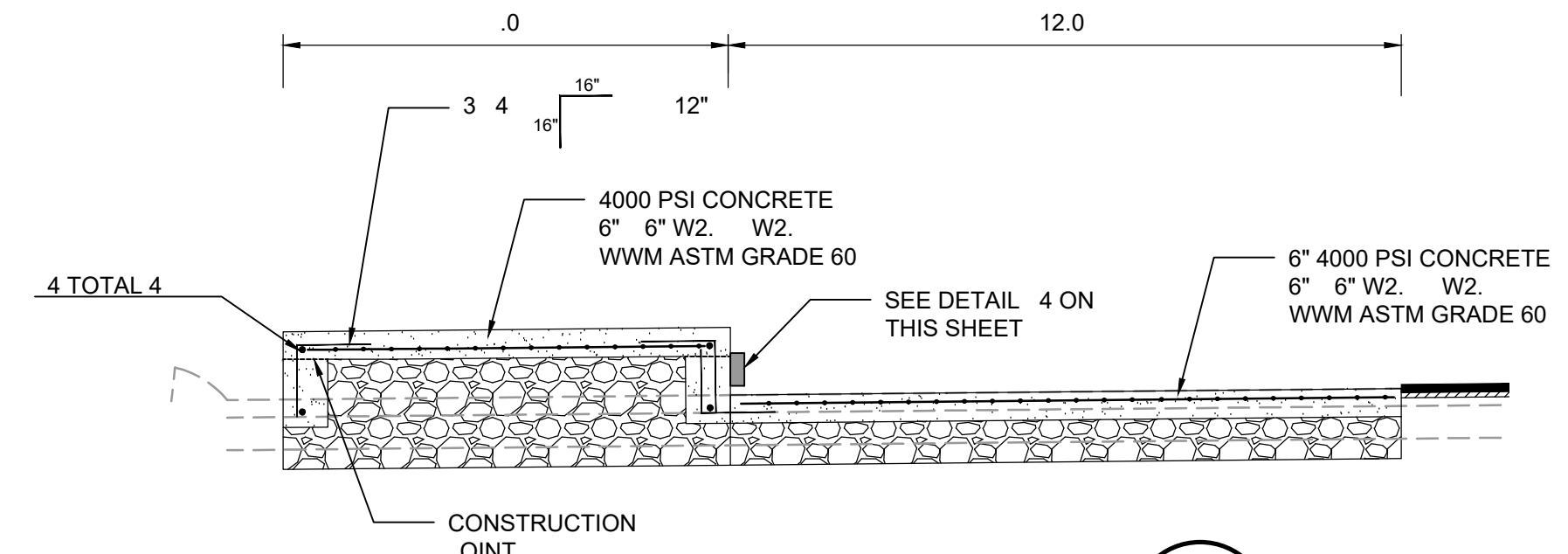

**CONCRETE PLATFORM**  
 3  
 1"=3'  
 C-2

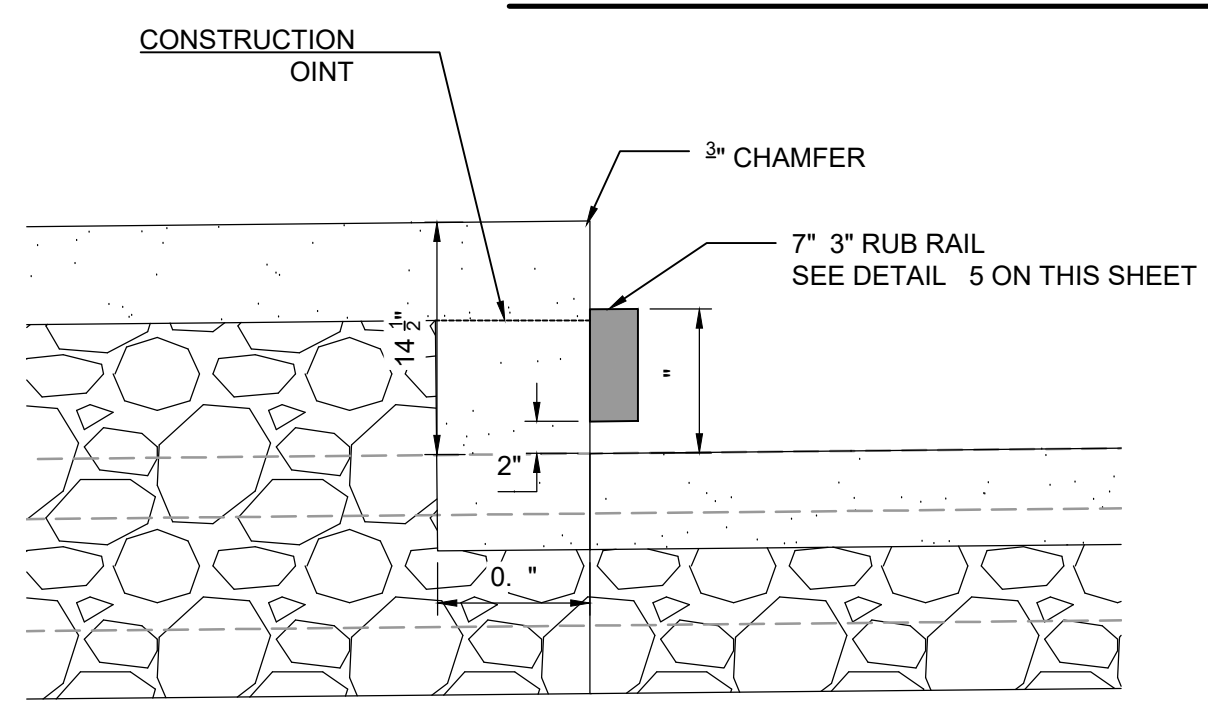

**CONCRETE PLATFORM**  
 4  
 1"=1'  
 C-2

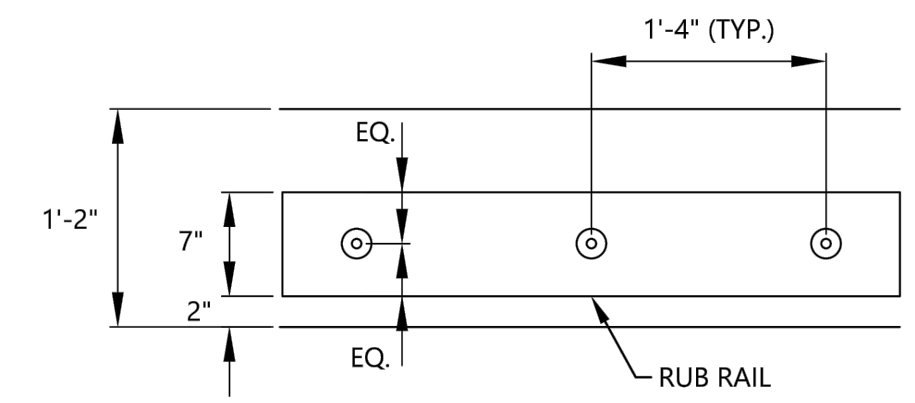

**POLYSLICK BUS CURB**  
 TYPICAL PROPERTIES

| Property*                                 | ASTM Test Method | Typical Values                  |
|---|------------------|---------------------------------|
| <b>Physical and Mechanical Properties</b> |                  |                                 |
| Density                                   | D792             | 0.932 g/cc                      |
| Tensile Strength @ Yield                  | D638             | 3,500 psi                       |
| Elongation at Break                       | D638             | 300%                            |
| Coefficient of Friction, Static           | D1894            | 0.2                             |
| Coefficient of Friction, Kinetic          | D1894            | 0.15                            |
| Abrasion Resistance **                    | - - -            | 10                              |
| Izod Impact Strength                      | D4020, Method A  | > 100 KJ/m <sup>2</sup>         |
| Durometer Hardness                        | D2240            | 64 Shore D                      |
| Water Absorption @ Saturation             | D570             | 0.01%                           |
| <b>Thermal Properties</b>                 |                  |                                 |
| Melting Point                             | - - -            | 271°F                           |
| Coefficient of Linear Thermal Expansion   | D696             | 8.3 X 10 <sup>-5</sup> in/in/°F |
| Flammability, UL 94                       | 1/8 inch         | HB                              |
| <b>Electrical Properties</b>              |                  |                                 |
| Dielectric Strength                       | D149             | 90.3 KV/m                       |
| Dielectric Constant                       | D150             | 2.3                             |
| Volume Resistivity                        | D257             | 1 X 10 <sup>14</sup> ohm-cm     |
| Surface Resistivity                       | D257             | 1 X 10 <sup>12</sup> ohm        |

**POLYSLICK BUS RUB RAIL**  
 5  
 N.T.S. C-2

| REV. NO. | DATE | DRWN | CHKD | REMARKS |
|----------|------|------|------|---------|
|          |      |      |      |         |

DESIGNED BY: JORGE RENTERIA  
 DRAWN BY: CARLOS SILVA  
 SHEET CHK'D BY: \_\_\_\_\_  
 CROSS CHK'D BY: \_\_\_\_\_  
 APPROVED BY: \_\_\_\_\_  
 DATE: AUGUST 2024

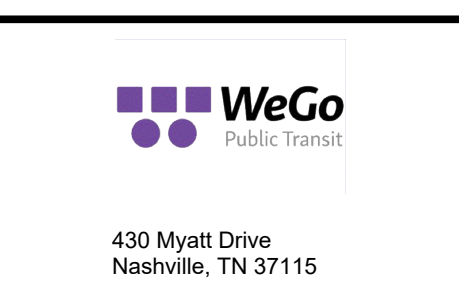
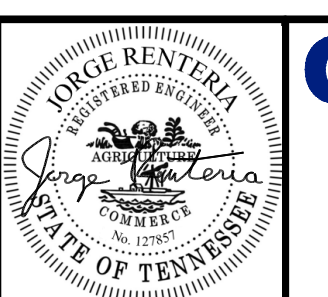

WeGo PUBLIC TRANSIT  
**MYATT PARKING LOTS REHABILITATION**

**CONSTRUCTION DETAILS**  
 SHEET NO.  
**C-4**

DRAWING SCALE: 1" = 1'  
 PROJECT NO: 289548  
 FILE NAME: C-4

© 2024 CDM SMITH ALL RIGHTS RESERVED. REUSE OF DOCUMENTS: THESE DOCUMENTS AND DESIGNS PROVIDED BY PROFESSIONAL SERVICE, INCORPORATED HEREIN, ARE THE PROPERTY OF CDM SMITH AND ARE NOT TO BE USED, IN WHOLE OR PART, FOR ANY OTHER PROJECT WITHOUT THE WRITTEN AUTHORIZATION OF CDM SMITH.

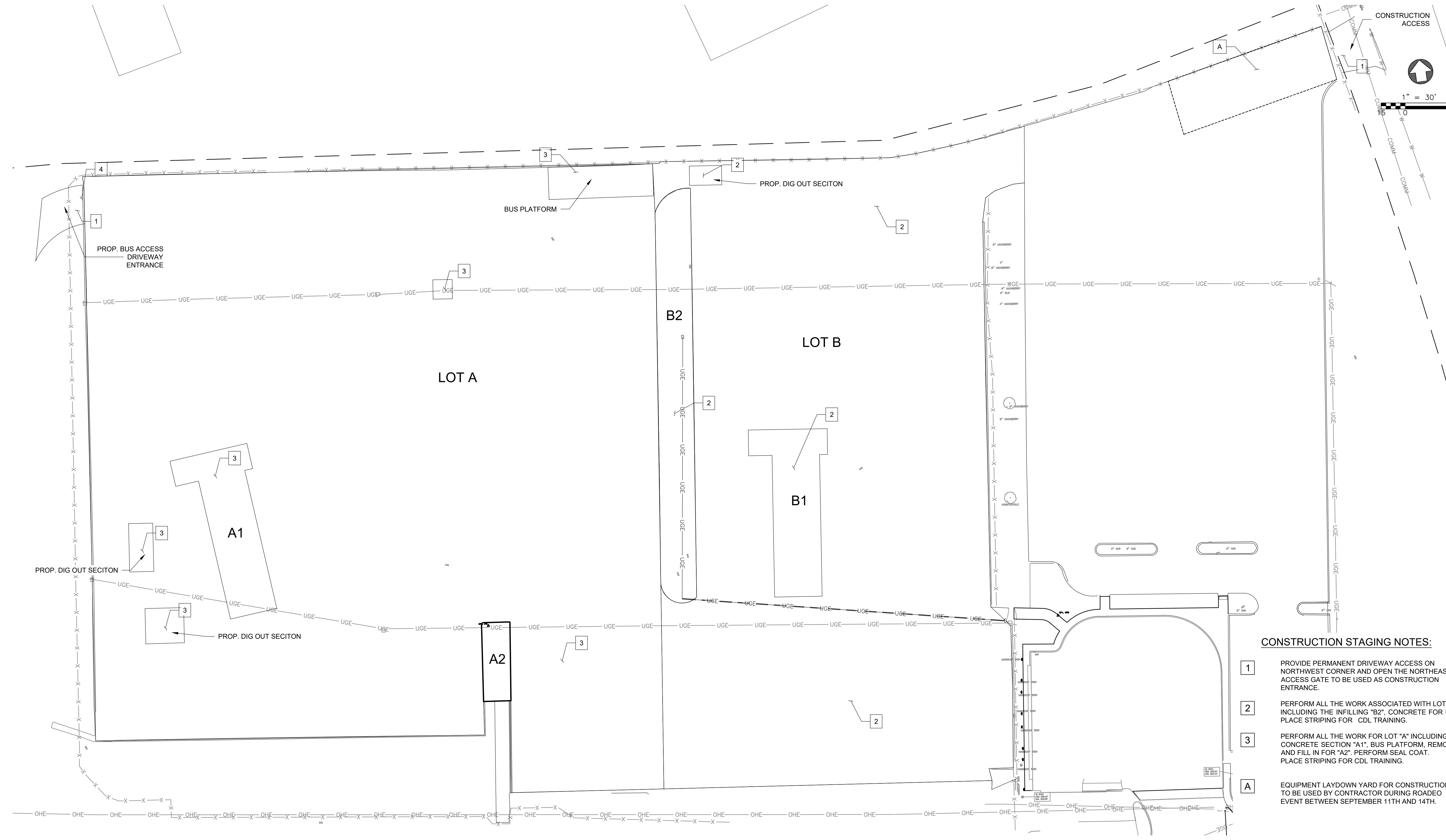

**CONSTRUCTION STAGING NOTES:**

- 1** PROVIDE PERMANENT DRIVEWAY ACCESS ON NORTHWEST CORNER AND OPEN THE NORTHEAST ACCESS GATE TO BE USED AS CONSTRUCTION ENTRANCE.
- 2** PERFORM ALL THE WORK ASSOCIATED WITH LOT B INCLUDING THE INFILLING "B2", CONCRETE FOR B1 & PLACE STRIPING FOR CDL TRAINING.
- 3** PERFORM ALL THE WORK FOR LOT "A" INCLUDING CONCRETE SECTION "A1", BUS PLATFORM, REMOVAL AND FILL IN FOR "A2". PERFORM SEAL COAT. PLACE STRIPING FOR CDL TRAINING.
- A** EQUIPMENT LAYDOWN YARD FOR CONSTRUCTION TO BE USED BY CONTRACTOR DURING ROADEO EVENT BETWEEN SEPTEMBER 11TH AND 14TH.

| REV. NO. | DATE | DRWN | CHKD | REMARKS |
|----------|------|------|------|---------|
|          |      |      |      |         |
|          |      |      |      |         |
|          |      |      |      |         |

DESIGNED BY: JORGE RENTERIA  
 DRAWN BY: CARLOS SILVA  
 SHEET CHK'D BY: \_\_\_\_\_  
 CROSS CHK'D BY: \_\_\_\_\_  
 APPROVED BY: \_\_\_\_\_  
 DATE: AUGUST 2024

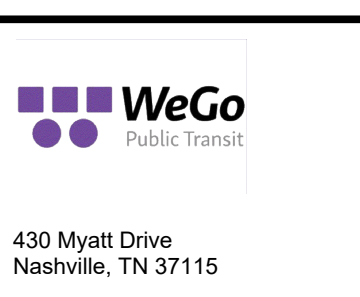

WeGo PUBLIC TRANSIT  
**MYATT PARKING LOTS REHABILITATION**

**CONSTRUCTION STAGING**

DRAWING SCALE: 1" = 30'  
 PROJECT NO: 289548  
 FILE NAME: C-5  
 SHEET NO.  
**C-5**